

**Bogenanlagekontrolle**  
**Sheet alignment control**  
**Détecteur contrôle**  
**de marge de la feuille**

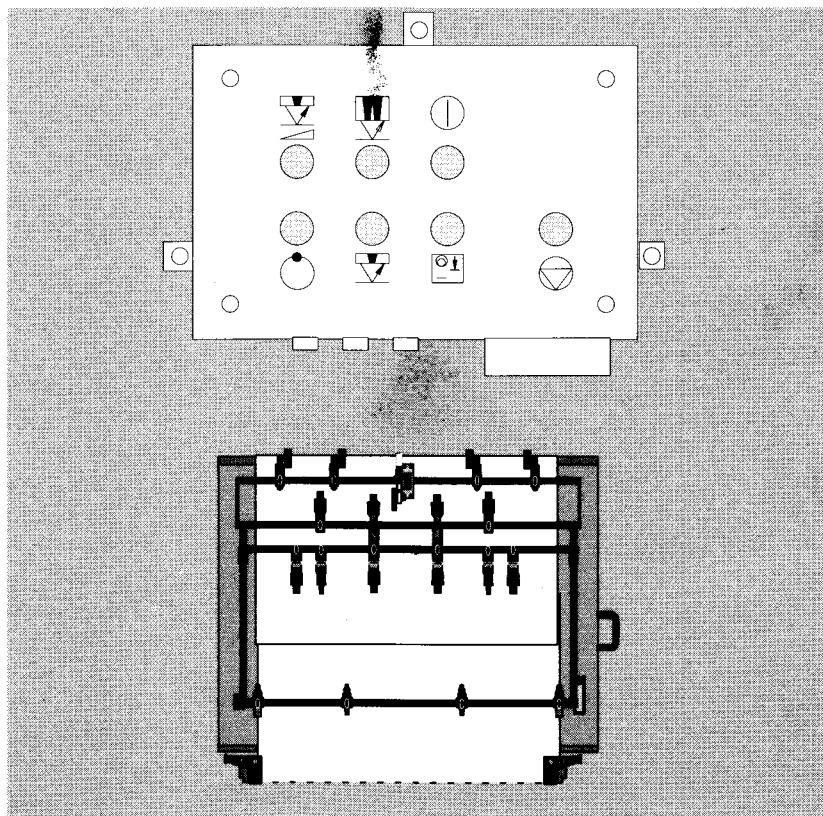

**D**

## **Bogenanlagekontrolle**

- 1.3 **Sicherheitshinweise**
- 1.4 **ESD-Schutzmaßnahmen**
- 1.5 **Funktionsbeschreibung**
- 1.8 **Bogenanlageelektronik BAE**
- 1.9 **Reflexlichtschranke RL 2**
- 1.10 **Abfrageschalter AS**
- 1.11 **Stichwortverzeichnis**

**GB**

## **Sheet alignment control**

- 2.3 **Safety instructions**
- 2.4 **ESD protective measures**
- 2.5 **Description of functions**
- 2.8 **Front alignment sheet control BAE**
- 2.9 **Reflection light barrier RL 2**
- 2.10 **Control switch AS**
- 2.11 **Index**

**F**

## **Détecteur contrôle de marge de la feuille**

- 3.3 **Instructions concernant la sécurité**
- 3.4 **Mesures de protection ESD**
- 3.5 **Description du fonctionnement**
- 3.8 **Contrôle électronique des feuilles à la marge BAE**
- 3.9 **Cellule réflexe RL 2**
- 3.10 **Interrupteur de contrôle AS**
- 3.11 **Index alphabétique**



## Important safety instructions

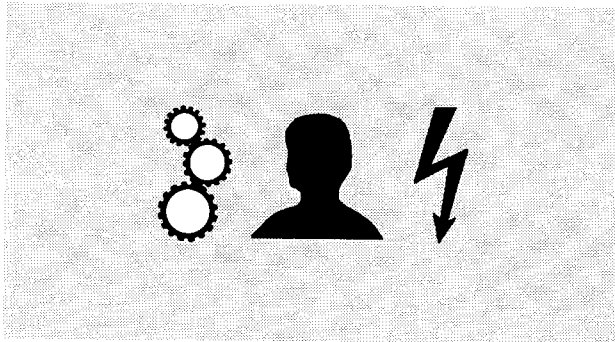

- Observe the general and press-specific safety instructions in the operating manual.
- At first start-up or after the exchange of equipment or components check the correct functioning of all safety equipment.
- Control cabinet and machine housing have to be locked while the press is in operation. They may only be opened for repair purposes.
- Make sure that the main power switch is turned off and that there is no voltage applied to the press before you open the control cabinet or the machine housing.
- If it is necessary to repair the press while it is connected to the mains supply, please pay attention to general safety precautions.
- Never exchange components and units while the press is connected to the mains supply.
- Safety equipment must not be modified. Do not remove earth conductors. If it is necessary to disconnect these conductors, please remember to reconnect them after you are finished.
- If extra accessories not corresponding to Heidelberg specifications are installed or mounted, Heidelberg does not accept any liability whatsoever. In each case these accessories must be controlled or locked in a way that no hazards can arise when the press and its devices are operated.

**Caution:**



**Observe the handling instructions when replacing electronic boards incorporating electrostatically sensitive components!**

## Handling and replacing electronic boards

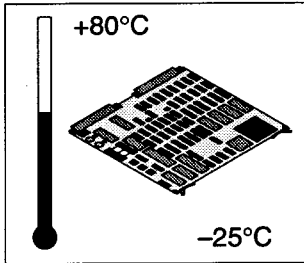

**Storage:**  
**NEVER** below  $-25^{\circ}\text{C}$   
**NEVER** above  $+80^{\circ}\text{C}$

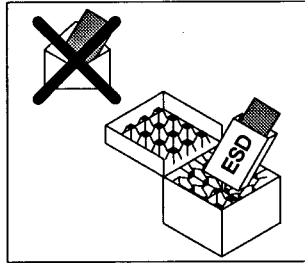

**ALWAYS**  
pack away into ESD  
protective container.

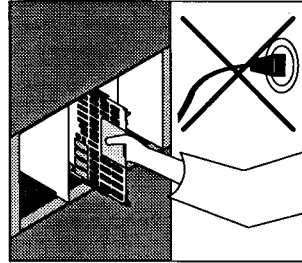

**NEVER**  
replace when power is  
on.

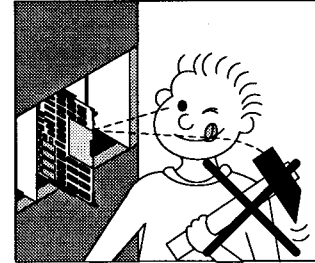

**NEVER**  
use force to insert.

## ESD protective measures to be observed when replacing electronic boards

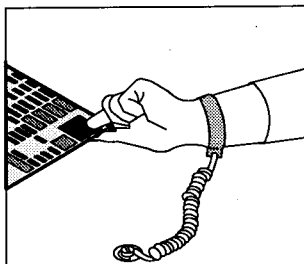

**DISCHARGE**  
static charges.

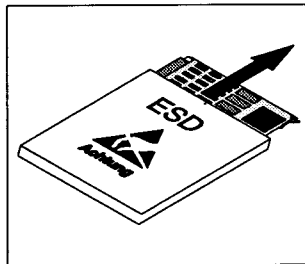

**UNPACK**  
from ESD protective  
container.

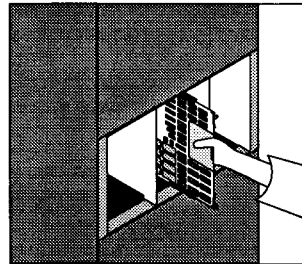

**REPLACE**  
electronic boards.

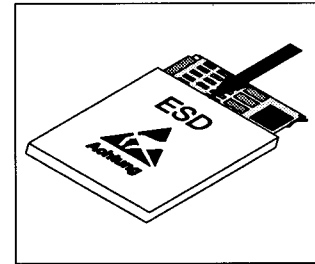

**PACK**  
into ESD protective  
container.

## Sheet alignment control

### Description of functions

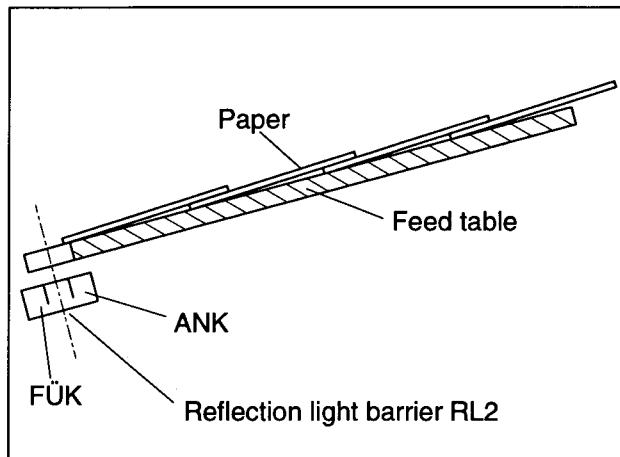

Schematic representation

The reflection light barrier RL2 comprises:

ANK = sensor for sheet alignment control

FÜK = sensor for overshooting sheet control.

The ANK sensors register:

- early sheets (first sheet)
- late sheets (missing sheets)
- misaligned sheets.

The FÜK sensors register:

- overshooting sheets.

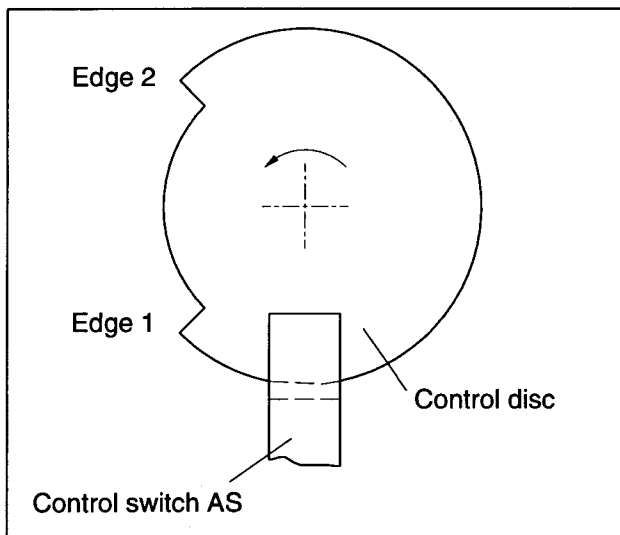

Control points

#### Control disc, edge 1:

"Feeder on" function (if push button has been pressed). The first sheet must not have reached the front lays before this moment (front lays in resting position).

#### Control disc, edge 2:

Front alignment and early sheet control and "feeder off" function (if push-button has been pressed). At this moment the sheet must lie properly at the front lays. The degree position for the arrival of edge 2 at the control switch has been chosen so that there is sufficient time for execution of the impulses reported by the electronics (magnet, clutch solenoid) when a misfed sheet has been detected.

The electronical front alignment control in S-Offset presses consists of:

|                |                                       |
|----------------|---------------------------------------|
| BAE            | the sheet front alignment control box |
| RL2            | the reflection light barrier          |
| AS             | the control switch                    |
| SORM / SORM-Z: | BAE; 1 x RL; 1 x AS                   |
| SORS / SORS-Z: | BAE; 2 x RL; 1 x AS                   |

The electronics box BAE has been designed as a compact unit assembled from integrated circuits. The lighting-up of diodes in the lid of the box makes it possible the faults are spotted immediately and adjustments can be made more easily.

The recessed disc which rotates synchronously with the machine determines in conjunction with the switch AS the moments at which the sheet is being checked. The reflection light barrier RL reports the position of the sheet as it arrives at the alignment control line to the electronical device BAE. The latter then interconnects all signals in the right order and gives the appropriate command to the machine (for example, "feeder stop", "impression on").

#### Correct sheet travel:

After "Feeder on" and "Paper on" the first sheet is transported over the feed table to the front lays and passes the sensors of the reflection light barrier RL2. The first sheet must arrive at the front lays between control point 1 (control disc, edge 1) and control point 2 (control disc, edge 2). If the sheet is properly aligned, it is checked at edge 2 and impression is thrown on if preselected.

#### Misaligned or late sheet:

If during printing process a sheet is aligned slanted or too late so that at control moment 2 no light barrier – or only one – is covered feeder motion and impression are stopped. Machine continues running at lowest speed.

#### Overshooting sheet:

If a sheet covers the FÜK sensors on the reflection light barrier at control moment 2 during sheet run, the feeder is disengaged. After one more machine rotation when impression has been switched off mechanically machine stops.

#### Early sheet:

If the first sheet arrives outside the two control points 1 and 2 (recess in control disc), the feeder is switched off and the machine stops immediately.

#### Push-buttons "Feeder on", "Feeder off":

Control point 1 (control disc, edge 1) is for "Feeder on". "Feeder on" must be pressed until point 1 has passed the switch. Passage engages feeder electronically. Control point 2 relates to the disengagement of the feeder. Pressing the button "Feeder stop" automatically switches the feeder off at control point 2.

## Adjustment of control disc with control switch

2 control discs with different recesses are used.

### Disc type 1:

Recess of about  $97^\circ$

In SORS-Z

### Disc type 2:

Recess of about  $82^\circ$

In SORM-Z

Edge 2 of the control disc (in direction of rotation "Forward" – end of recess) only serves to adjust the control points. Using the "90° angle" (of the gripper bar to the feed table) as the point of reference for control adjustment, point 2 of the disc should pass the switch at the following machine times:

### SORM / SORS:

Graduated disc for the  $90^\circ$  angle position set at  $85^\circ 30'$

machine time =  $57,5^\circ \pm 0,5^\circ$

### SORM-Z / SORS-Z:

Graduated disc for the  $90^\circ$  angle position set at  $318^\circ$

machine time =  $290^\circ \pm 0,5^\circ$

This means that a single-colour offset press must first be brought into the  $90^\circ$  gripper bar/feed table position and the graduated disc be set at  $85^\circ 30'$ . Then inch machine back to  $57^\circ 30'$ . Now move the point 2 of the recessed disc into the slot of the switch so that the light diode just goes on or off.

## Adjustment of the reflection light barrier RL2

For exact adjustment proceed as follows:

Pull back sheet 1 to 1.5 mm from the front lay guides and move the reflection light barrier by turning the adjustment screw until the adjustment indicating diodes on the electronics box BAE light up or go off.





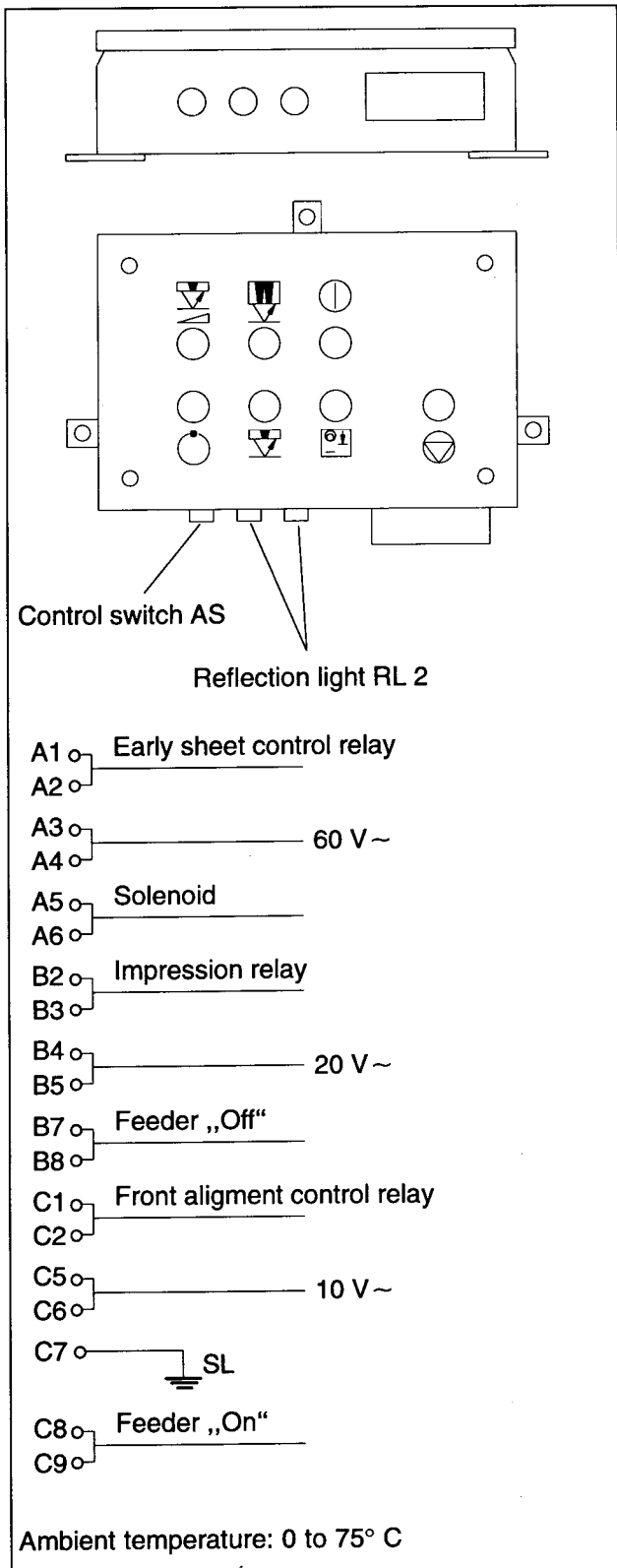

If the press is equipped with two reflection light barriers one of them must be covered when the other one is being adjusted as described above. After that, cover the light barrier that has already been adjusted and adjust the other one.

### Front alignment sheet control BAE



Contact assignment

### Symbols and their meaning

- 
**Timing of the control disc**  
 Lights up, when the recess at the control disc passes the control switch AK 8. That means, the diode lights up once at each turn of the machine.
- 
**Operation**  
 Lights up, as soon as the electronics are ready for operation.
- 
**ANK-Front alignment control**  
 Lights up, as long as the ANK of at least one light reflection barrier recognizes a sheet of paper.
- 
**FÜK-Early sheet control**  
 Lights up, as long as the FÜK of at least one light reflection barrier recognizes a sheet of paper.
- 
**Impression**  
 Lights up, when the machine is prepared to go on impression. It also lights up when „preset speed“ was not activated.
- 
**Malfunction**  
 Lights up, when feeder is stopped or a fault has been recognized by the electronics that stopped the feeder.
- 
**Indication of adjustment**  
 Lights up, when the ANK - signals are fed into the electronics in proper connection, that means:
  1. with only one reflection light barrier connected to the electronics box the diode lights up, as long as a sheet of paper is recognized by the ANK in the reflection light barrier.
  2. with two reflection light barriers connected to the electronics box the diode lights up, as long as a sheet of paper is recognized by the ANK in both reflection light barriers.

English

## Reflection light barrier RL 2

### Layout

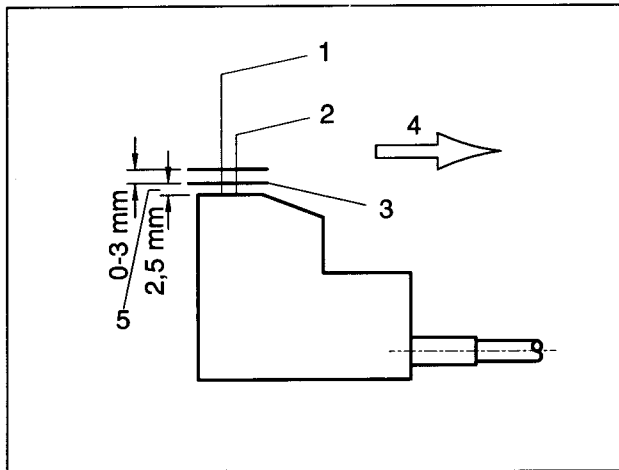

Reflection light barrier RL2

- 1 ANK Sensor for sheet alignment control
- 2 FÜK Sensor for overshooting sheet control
- 3 Feed table surface
- 4 Direction of paper transport
- 5 Working distance

### Socket connection

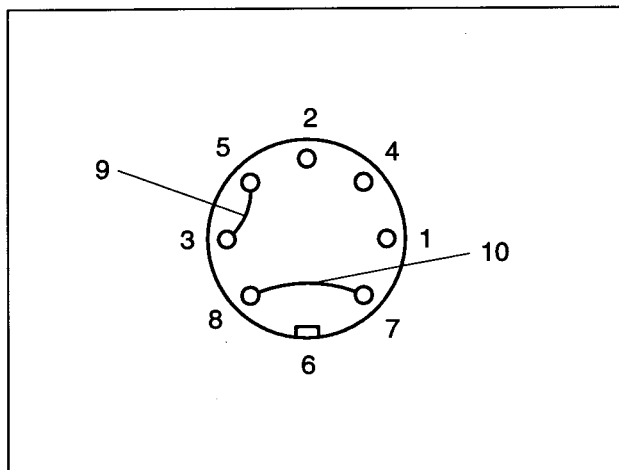

Socket connection RL2

- 1 Transmitter
- 2 ANK sensor
- 3 +U<sub>B</sub>
- 4 FÜK sensor
- 5 SL
- 6 Free
- 7 Shield
- 8 ⊥ (ground)
- 9 Connecting wire between contacts 3 and 5
- 10 Connecting wire between contacts 7 and 8

## Control switch AS

### Layout

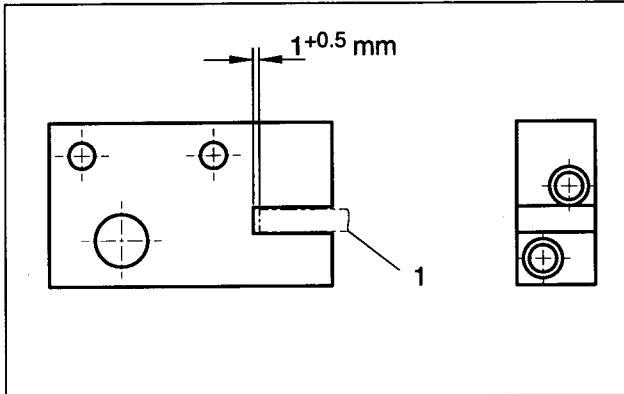

Control switch AS

1 Control disc

Working frequency:

5 Hz

Control disc:

Steel 1.5 mm

Protection:

IP 65

### Socket connection

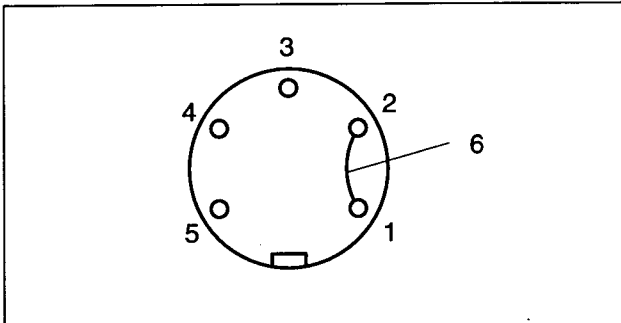

Socket connection control switch AS

1 Free

2 +U<sub>B</sub>

3 Output

4 ⊥ (ground)

5 Shield

6 Connecting wire between contacts 1 and 2

**Index****A**

- ANK-sensor, 2.5
- Early sheet, 2.5
  - Late sheet, 2.5
  - Misaligned sheet, 2.5

**C**

- Control disc, 2.5
- Adjustment with control switch, 2.7
- Control switch AS, 2.6
- Layout, 2.10
  - Socket connection, 2.10

**E**

- Early sheet, 2.6
- edge 1, 2.5
- edge 2, 2.5

**F**

- Front alignment sheet control BAE, 2.8
- FÜK-sensor, 2.5
- Overshooting sheet, 2.5

**M**

- Misaligned or late sheet, 2.6

**O**

- Overshooting sheet, 2.6

**P**

- Push-buttons "Feeder on", "Feeder off", 2.6

**R**

- Reflection light barrier RL2, 2.5
- Adjustment, 2.7
  - Layout, 2.9
  - Socket connection, 2.9
  - Working distance, 2.9

**S**

- Sensors, – Sheet alignment control. See ANK/FÜK-sensor, 2.5
- Sheet alignment control, 2.5
- Description of functions, 2.5
- Sheet front alignment control box, 2.6
- Sheet travel, 2.6
- Symbols, 2.8
- ANK-Front alignment control, 2.8
  - FÜK-Early sheet control, 2.8
  - Impression, 2.8
  - Indication of adjustment, 2.8
  - Malfunction, 2.8
  - Operation, 2.8
  - Timing of the control disc, 2.8



## Copyright

Printed in Germany.

Diese Technische Beschreibung ist unser alleiniges Eigentum und wird nur leihweise überlassen. Sie ist ausschließlich bestimmt zur Durchführung des Heidelberger Kundendienstes durch unsere autorisierten Vertretungen. Übersetzung, Weitergabe an Dritte sowie jede Vervielfältigung und Verbreitung sind ohne unsere vorherige schriftliche Zustimmung untersagt und werden nach den geltenden Gesetzen gerichtlich verfolgt.

Änderungen ohne Ankündigung vorbehalten.

Printed in Germany.

This Manual is our exclusive property and made available on loan only. It is exclusively intended for carrying out the Heidelberg service by our authorized agencies. Translation, transmission to third parties as well as any reproduction and circulation without our previous written consent are prohibited and will be prosecuted according to the laws presently enacted. Subject to alterations without notice.

Printed in Germany.

La présente Description technique est notre propriété exclusive et n'est remise qu'à titre de prêt. Elle est exclusivement destinée à la réalisation des travaux d'entretien et de réparation dans le cadre du Service après-vente Heidelberg par nos agences autorisées. Traduction, communication à des tiers ainsi que toute reproduction et diffusion sans notre permission écrite préalable sont strictement interdites et seront poursuivies d'après les lois et règlements en vigueur. Sous réserve de modifications sans préavis.

© Copyright by  
HEIDELBERGER DRUCKMASCHINEN AG,  
Kurfürsten-Anlage 52-60  
69115 Heidelberg, Germany

**HEIDELBERG**