

Table of contents

A Safety devices.....	A.1
Safety devices	A.1.1
1 Grundlegende Safety instructions	A.1.3
2 Technical data	A.1.11
3 Workshops on the machine.....	A.1.12
4 Controls	A.1.13
5 Guards	A.1.16
6 Business forms for a secured machine.....	A.1.28
7 Checking the guards.....	A.1.30
8 Turning the machine by hand	A.1.32
B Controlling the machine.....	B.1
Controlling the machine	B.1.1
1 Control console insert	B.1.3
2 Printing control areas	B.1.7
3 Paintwork control stations.....	B.1.9
4 Control console normal explanation.....	B.1.12
5 Control console high stack explanation	B.1.15
6 Machine-informatiedisplay (MID).....	B.1.18
7 CPTronic Control Console.....	B.1.24
8 Explanation control console for SM 74-1, SM 74-2 with normal stacking extension without CPC.....	B.1.41
9 Input at machines with KID	B.1.50
10 Cleaning the operating positions	B.1.62
Set up and print C.....	C.1
Presets.....	C.1.1
1 Machine Presets.....	C.1.3
2 Starting up the machine	C.1.7
3 Assignment change.....	C.1.8
4 Machines met KID	C.1.30
Zuigkop	C.2.1
1 Observe	C.2.3
2 Adjustments to the suction head.....	C.2.4
3 Losblazers.....	C.2.7
4 Rear stacking stops	C.2.9

8	To fix an issue.....	C.5.28	
9	Vacuum at the collecting drum.....	C.5.32	
	Ink work.....	C.6.1	
1	Observe	C.6.3	
2	Ink box with knife.....	C.6.4	
3	Selecting the operating mode of the ink tank roller	C.6.6	
4	Ink Tray Roller Adjustments	C.6.8	
5	Switching the lick roller and ink carrier rollers on/off.....	C.6.10	
6	Scale prints	C.6.11	
7	Automatic ink roller washing device	C.6.13	
8	Manual control of the ink roller washing device.....	C.6.15	
9	Detergent basic settings	C.6.16	
10	Lateral friction	C.6.18	
11	Ink work tempering	C.6.21	
	Moisture work	C.7.1	
1	Moisture work - observe during all work	C.7.3	
2	General.....	C.7.4	
3	Production	C.7.5	
4	Preselecting moisture work functions	C.7.6	
5	Blow list	C.7.8	
6	Cleaning rollers by hand	C.7.10	
7	Central moisture supply.....		C.7.11
8	Pre- and post-fights.....	C.7.13	
	Paintwork	C.8.1	
1	Observe	C.8.3	
2	Overview	C.8.4	
3	Paint supply device	C.8.5	
4	Transfer drum for paintwork.....	C.8.6	
5	Preparing for painting.....	C.8.7	
6	Replacing the paint cloth and backing sheet	C.8.9	
7	Lacquering	C.8.14	
8	Blowpipe above the pressure cylinder.....	C.8.16	
9	Preset functions	C.8.17	
10	Pressure adjustment	C.8.18	
11	Cleaning paintwork	C.8.24	
12	Selecting paint characteristics.....	C.8.26	
13	Printing technical instructions regarding varnishing	C.8.27	
	Numbers and impressions.....	C.9.1	
1	Safety instructions.....	C.9.5	

Integral chapter overview

2	General.....	C.9.6
3	CPTronic functions (CID)	C.9.7
4	CPTronic functions (KID).....	C.9.12
5	Preparations for Numbering and Printing.....	C.9.16
6	Sheet guide.....	C.9.21
7	Numeroteur and impression work.....	C.9.22
8	Seat rings and retaining rings	C.9.23
9	Montagewagen.....	C.9.25
10	Numbered.....	C.9.26
11	Numeroteur and impression inking.....	C.9.31
12	Dialers	C.9.37
13	Impressions	C.9.39
14	Pressure adjustment	C.9.40
15	Position corrections.....	C.9.41
16	Pressure force - pressure compensation	C.9.42
17	Switch cams.....	C.9.43

The perforator C.10.1

1	Observe	C.10.3
2	General.....	C.10.4
3	CPTronic features.....	C.10.5
4	Preparations for punching	C.10.7
5	Sheet guide.....	C.10.8
6	Longitudinal perforator in the explanation	C.10.9
7	Transverse perforation	C.10.12

Use..... C.11.1

1	Safety instructions.....	C.11.3
2	CPTronic features.....	C.11.4
3	Mechanical explanation adjustments.....	C.11.7
4	Blowing air for the auction guide on the high stack extension.....	C.11.9
5	Air setting explanation.....	C.11.13
6	Longitudinal blow pipes	C.11.15
7	Fans in the explanation	C.11.16
8	I would like to.....	C.11.17
9	Switching sheet equal tappets on and off.....	C.11.29
10	Test drawing	C.11.31
11	Adjustment of the auction catchers.....	C.11.32
12	Non-stop device.....	C.11.33
13	Powder device	C.11.37
14	IR-droger	C.11.41

D Adjustment and maintenance	D.1
Inlay.....	D.1.1
1 Observe	D.1.3
2 The beat roll	D.1.4
3 Maintenance of the suction head.....	D.1.5
Printing	D.2.1
1 Observe	D.2.3
2 Cleaning and maintenance	D.2.4
3 Rubberdoekcilinder	D.2.5
4 Rubber cloth/pressure cylinder washing device.....	D.2.12
Cleaning and weather printing, Transfer drums	D.3.1
1 Observe	D.3.3
2 Transfertrommels.....	D.3.4
3 Structural chrome coating.....	D. 3.6
Ink work.....	D.4.1
1 Observe	D.4.3
2 Roles.....	D.4.4
3 Disassemble rollers 1 to 14.....	D.4.6
4 To assemble	D.4.11
5 Assembly and disassembly of the lick roller 15.....	D.4.20
6 CPC-inktbak	D.4.23
7 Roller washing device	D.4.26
8 Ink work tempering	D.4.27
Moisture work	D.5.1
1 Observe	D.5.3
2 Roles.....	D.5.4
3 Treatment of the moisturizer	D.5.14
Paintwork	D.6.1
1 Observe	D.6.3
2 Lakbak	D.6.4
3 Lakdompelrol.....	D.6.6
4 Transfer drum for paintwork.....	D.6.9
5 Paint supply device	D.6.10
Numbers and impressions.....	D.7.1
1 Impression inkwork.....	D.7.3
2 Dialers.....	D.7.10
3 Lubrication and maintenance	D.7.11
Explanation.....	D.8.1

Integral chapter overview

1 Observe D.8.3

2 Stacking plate..... D.8.4

3 Super Blue cloth on the delivery drum..... D.8.6

4 Oil collection plates D.8.9

5 Powder device D.8.10

General maintenance..... D.9.1

1 Observe D.9.3

2 Automatic lubrication D.9.4

3 Manual lubrication D.9.9

4 Filter regulator..... D.9.10

5 Cleaning the air filter D.9.11

6 Additional equipment D.9.14

7 Manual maintenance work D.9.15

8 Specification of the lubricants..... D.9.22

E Keyword index..... E.1

Safety devices

1 Grundlegende Safety instructions A.1.3

- 1.1 Safety instructions and general instructions A.1.3
- 1.2 Application purpose.....A.1.5
- 1.3 Your personal safety equipment A.1.5
- 1.4 Cleaning agents, inks, solvents and varnishes (flammable liquids) ... A.1.6
- 1.5 Working on the machine without danger.....A.1.8

2 Technical data..... A.1.11

- 2.1 Material to be printed A.1.11
- 2.2 Printing ink A.1.11
- 2.3 Noise emission values A.1.11
- 2.4 Maximum weight of the paper stack..... A. 1.11
- 2.5 Electrical protection of the machine A.1.11

3 Workshops on the machine..... A.1.12

- 3.1 Description of the workshops..... A.1.12

4 Controls..... A.1.13

- 4.1 Main switch.....A.1.13
- 4.2 Mushroom pushbutton EMERGENCY STOP A.1.14
- 4.3 PROTECT button A.1.15

5 Guards..... A.1.16

- 5.1 Fixed guards..... A. 1.16
- 5.2 Movable guards..... A.1.18
- 5.3 Shields on the numeroteur ink work A.1.21
- 5.4 Guards on high stack layout..... A.1.22
- 5.5 Shields on the paintwork..... A.1.23
- 5.6 Extended explanation of shields..... A.1.24
- 5.7 Other shields..... A.1.25

6 Operating modes for secured machines A.1.28

- 6.1 Tip operation with stroke limitation A.1.28
- 6.2 Tip operation without stroke limiter..... A.1.28
- 6.3 Creep speed operationA.1.29
- 6.4 Positioning..... A.1.29

Paragraph overview

7 Checking the guards A.1.30

7.1 Controleproces A.1.30 7.2

Storingssymbolen A.1.31

8 Turning the machine by hand A.1.32

8.1 Single color machine A.1.32

8.2 Multi-color machine..... A.1.33

1 Grundlegende Safety instructions

1.1 Safety instructions and general instructions

This manual contains three categories of instructions, which are explained below.

To clarify the individual instructions are associated with each category of symbols (pictograms) assigned a fixed meaning. Some of the contents of the pictograms are also applied to the printing machine as stickers.

Designation of the first category

This safety instruction warns you of potentially dangerous situations. If these instructions are ignored, serious injuries may occur be the result of this. In extreme cases there is there is danger to life! In addition, machines and... auxiliary equipment is seriously damaged.

Associated pictograms with signal words:



**Warning - <General hazard
ren>**



**Warning - Dangers due to electrical
Zt/ian current!**



Warning - Hot surface!



**Warning - Spinning reels, ci'
linders or gears!**



Warning - Spinning chains!

Safety devices

-H=JD=LB=RG-

Example:



Warning - Rotating cylinders!

Carelessness can lead to entrapment
lead by the fingers! When cleaning
of the cylinders should be in the palm of the hand
In the direction of the entry slit, point your fingers
in the direction of the exit slit! The direction of rotation
must be chosen accordingly
was

Designation of the second category

This safety instruction warns you of possible hazardous
situations. Become
If these instructions are ignored, damage to machines and
auxiliary equipment may occur
to arise.

Associated pictogram with signal word:



**Beware - <Brief description of it
danger>**

Example:

Caution - Damage to the tension shaft on the rubber cloth cylinder!

Before using the open-end wrench
Remove, otherwise the tensioning shaft will be
damaged.

Designation of the third category

This clue gives you additional information and
usage tips regarding the use of printing machines and associated
auxiliary equipment.

Associated icon with clue word:

ÿ Note

Example:

ÿ Note

None for materials up to 0.3 mm thick
adjustment of the feed drum is necessary.

1.2 Application purpose

The machine is suitable for printing flexible fabrics in the form of plates with a thickness of max. 0,6 mm.

The machine may only be used by trained personnel persons are operated and put into operation. The installation, conversion and disassembly of the machine may only be carried out by authorized Heidelberg service technicians.

The user is obliged to comply with national safety regulations and prevention regulations to monitor accidents.

By using the machine for materials that does not meet its intended purpose and/or by you not complying with the safety and/or terrestrial instructions Preventing accidents can cause danger originated for

- your life,
- your health,
- machines and installations.

ÿ Note

Abbreviations used in this manual:

AZ = drive side
BZ = operating side
LED = light diode
DW = printing

Protections on the machine

- do not disassemble,
- don't manipulate,
- don't dodge,
- Check daily for proper operation.

1.3 Your personal safety equipment

Wear when working on the machine

- safety shoes,
- tight-fitting clothing,
- if necessary, a hair net,
- when refilling chemicals, wear safety gloves,
- no jewellery, watches, etc. that can fall through grippers, moving machine parts or roller entry gaps can be caught.

1.4 Cleaning agents, inks, solvents and lacquers (flammable liquids)

Cleaning agents, inks, solvents and lacquers can be flammable, explosive, corrosive, poisonous, volatile, therefore observe the following instructions:

General instructions

- Ensure good ventilation.
- No open flames, no sources of ignition.
 - Anti-explosion safety features take into account.
 - Do not smoke, drink or eat when working with these substances.
 - Wear safety gloves.
 - Do not heat above their flash point.
- The applicable prevention regulations of accidents, safety regulations and - data sheets of the respective manufacturer follow up.
 - Only use cleaning agents, inks, solvents and lacquers with a flash point of at least 55 °C.
 - Store only in suitable containers.
 - Do not store near the machine or in the vicinity of UV and IR dryers.
- Spilled material immediately in a professional manner to delete.
 - Dispose of released waste according to regulations.

Safety devices

Instructions for the detergent reservoir

- Before opening the closures of the pressure reservoir for the ink roller, printing cylinder and rubber cloth washing device as well as the pressure reservoir of the paint cloth washing device, close the pressure air supply line and vent the reservoir.
- Heat sources away from the detergent keep the reservoir under the platform at BZ.

Dryer instructions

- When using dryers, only inks and use lacquers that are heated by heating the dryer cannot create **an explosive atmosphere** . This is stated in the safety data sheet when the explosion limit is stated under the instruction *not applicable*.
- When **using solvents** on the machine (e.g., during manual cleaning). no solvents end up in or near the dryer. **When washing** automatically Adjust the washing program so that rubber cloths and printing cylinders are dry when continuing production, so that no detergent can get into or ends up in the dryer. Also not allowed solvents are used or stored near the dryer. Because of the heating otherwise there is a risk of explosion from the solvents.



Warning - Hot surface!

Be careful when working on the dryer module!
During operation
high temperatures arise at the dryer module.

Safety devices

-H=ID=LB=RG-

1.5 Working on the machine without danger

Check this before starting the machine

- no one is within moving range machine parts.
- gates and handles are firmly installed.
- guards, covers and moving machine parts properly mounted and secured are.
- no foreign objects can get into the machine (eg tools lying around or falling down).

During operation

- during work in the area of the deposit not under moving parts (e.g., lifting and... trailing suction dredgers) and adjacent components (risk of pinching fingers).
- When working in the material inlet area, pay attention to dangerous movements (danger of injury). Not in the crack grab between shielding and material inlet.
- the running machine is always under supervision to hold.
- keep unauthorized persons out of the danger zone ren.
- when working on the folded and when the ink box is attached, be particularly careful watch the movement of the ink box roller.
- when working in the explanation area (stack changing, taking out a test, working with wedges) especially on the movement of the chain grab bridges (danger to life).

Set-up, cleaning and maintenance

carry out as follows, as this involves an increased risk of injury consists of:

- With utmost caution and carefulness.
- When cleaning the cylinders, the palms point towards the retraction opening and the fingers point towards the discharge opening (for this the choose the correct direction of rotation).
- If possible, always when stationary or protected machine.
- In areas with tip—operation with stroke limitation Only trained personnel may be employed.

- Only clean the folded ink box when the ink box roller is at a standstill. The Always point fingers away from the input opening.
- The mounting openings may only pass through the service personnel are used. For the use of the mounting holes switch main switch to OFF and with a secure padlock.
- The instructions for maintenance of the machine (chapter D Adjustment and maintenance) follow up. Inadequate or insufficient maintenance of the machine can result in risks that can easily be avoided.

For all work under the machine, in the inlay, in the explanation or on aggregates (dryer, cooling equipment, central air supply, etc.):

The main switch

- switch to OFF,
- secure with a padlock,
- secure against being switched on again.

Safety devices

After switching off the machine, pay attention to the following

- The fans of the explanation and the blowers of the generators will still be approximately one minute.
- Dryer(s) and additional equipment are available are still hot. Therefore, allow the dryer(s) and other equipment to cool down before carrying out any work on them.

In the event of a malfunction or failure of a security system

- stop the machine immediately.
- Immediately notify the service department of your Heidelberg agent.

Electrical devices

- only have it repaired and maintained by the authorized Heidelberg service.
- Switch cabinets and housings always closed to hold.

2 Technical data

2.1 Material to be printed

Maximum size: 53 x 74 cm.

Minimum formats:

- 21 x 28 cm in preprinting operation, • 28 x 28 cm in preprinting and reprinting mode, • 28 x 28 cm, when the machine is equipped with an insert stacking plate.

Maximum thickness: 0.6mm.

2.2 Printing ink

The machine is not suitable for processing inks with a flash point lower than 55 °C.

2.3 Noise emission values

According to DIN 45635, sheet 27:

- Noise level at the inlay: 84 dB (A)
- Noise level at the inieg control console: 80 dB (A)
- Noise level at the normal stack layout: 82 dB (A)
- Noise level at the high stack extension: 83 dB (A)

2.4 Maximum weight of the paper stack

- Insert: 350 kg
- Normal explanation: 190 kg
- High stack extension: 420 kg

2.5 Electrical protection of the machine

The values for the electrical protection of the machine are stated on the rating plate on the outside of the control cabinet.

Safety devices

3 Workshops on the machine

3.1 Description of the workshops

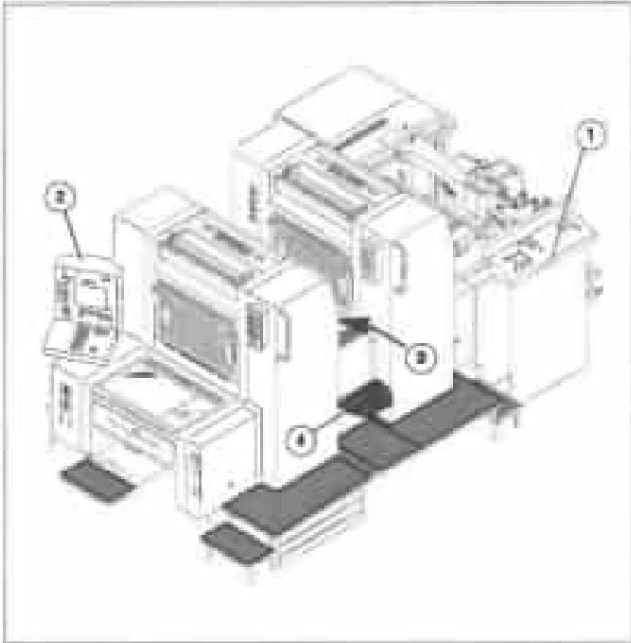

afb. 1

The following work stations are located on the machine:

- operating console on the inlay (fig. 1/©),
- control console at the explanation (fig. 1/©) or
- CPC control console,
- appearance and treads (marked gray),
- space for the inlet and outlet of the inserts explanation paper stacks.

OU may only use those parts of the machine tread on surfaces that are like treads (checker plate). (marked dark gray in Fig. 1).

○ The shields above the pressure cylinders and transfer drums (fig. 1 /©) only be entered at carry out adjustment or cleaning work on the ink tank.



Be careful - danger of falling!

Only via the steps (fig. 1 /©) get on and off at AZ. When getting on and off there is a risk of getting off at AZ fall down.

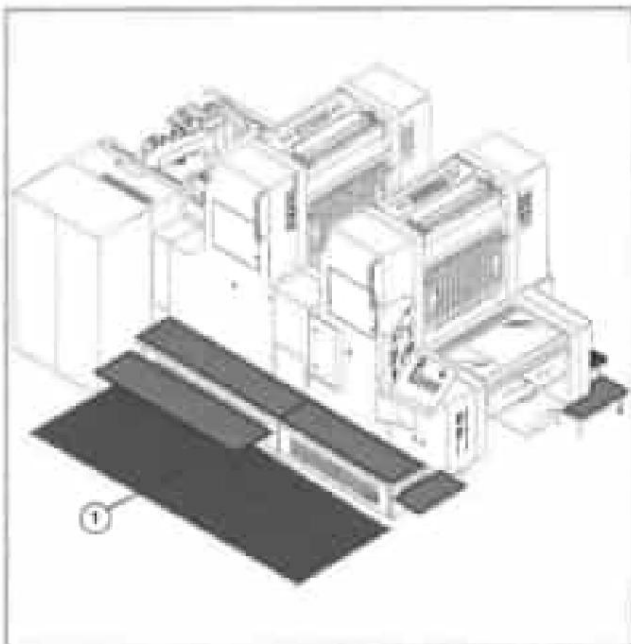

afb. 2

- Before **entering the front swing step** the explanation or to AZ make sure that the **step intervene correctly** and check this.
- Never use the workshop areas as a storage surface for tools, cleaning agents, etc
- Always keep workshop areas free of oil, grease and other liquids to avoid any risk of slipping.
- The space for the air outlets of Always keep the machine free to ensure proper cleaning to ensure heat dissipation (fig. 2/©). Never place spray boxes or barrels with volatile or flammable cleaning agents in this area.

4 Controls

4.1 Main switch

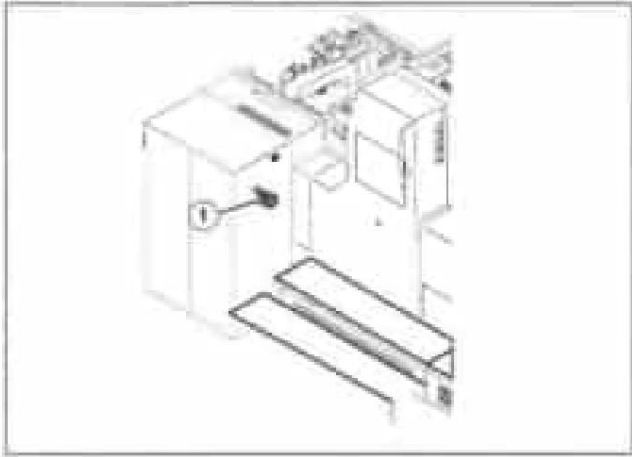

afb. 3

The main switch is located on the control box (fig. 3/0).

Note The main switch can be locked with a padlock. This allows the machine to be secured against being switched on.

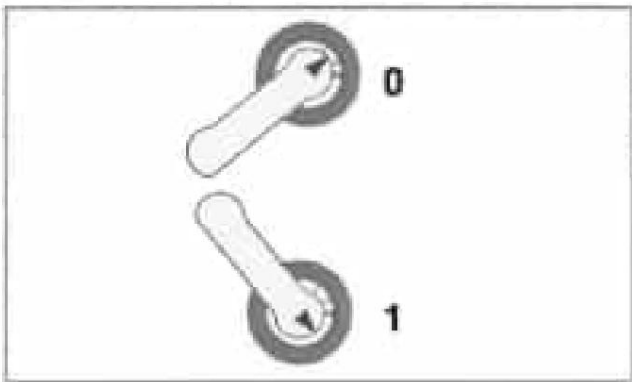

afb. 4

Shift lever positions (fig. 4):

- Switch lever in position 0 (off): machine is voltage-free
- Switch lever in position 1 (on): machine is in operation



Warning - electrical hazards flow!

The control box may only be opened by qualified electricians. Even when the main switch is turned off, parts in the switch cabinet are still live.

Safety devices

4.2 Mushroom push button EMERGENCY OFF

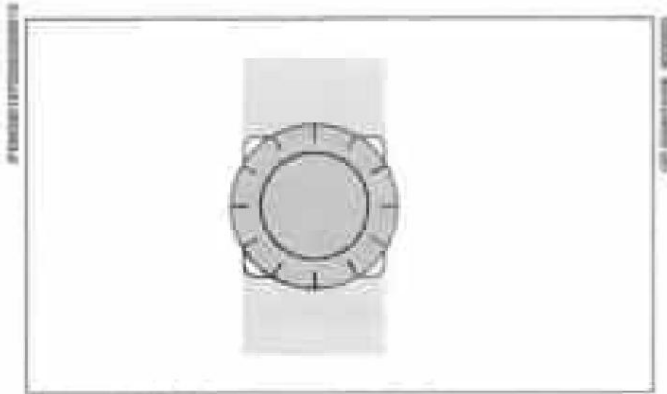

afb. 5

EMERGENCY STOP (fig. 5) is a red mushroom push button yellow background.

This is located at the following control points:

- control console insert
- operating positions at the printing works
- control console explanation
- CPTronic control console

When the mushroom pusher is operated, the machine immediately stops, except:

- moisture tray rollers and dosing rollers of the moisture works (under the shielding of the moisture works),
- ink baking rolls,
- lacquer tray roller and dosing roller.

The humidifier roller and the dosing roller can be stopped by opening the shield of the humidifier or by switching off the main switch. The

paint baking roller and the dosing roller can be stopped through the shield for the paint dipping roller and the dosing cylinder or by pressing the main switch to turn off. The ink box roller can be stopped by turning off the roller on the CPTronic control console or by switching off the main switch.

The mushroom push button EMERGENCY OFF becomes automatic locked. - To unlock, turn the mushroom pusher clockwise.



Warning - dangers due to electrical /scho current!

By operating EMERGENCY OFF the machine not tension-free. To disconnect the machine from the power supply, switch off the main switch.

4.3 PROTECT button

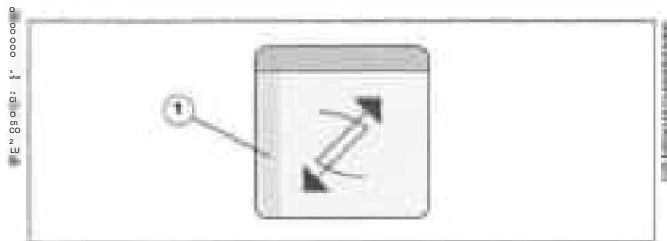

afb. 6

This button is located at the following control points:

- control console insert,
- operating positions at the printing works,
- control console explanation.

Secure the machine against commissioning

Q The button at one of the control points 2 press once (with an interval of max. 0.5 seconds). The LED (fig. 6/Q) lights up.



Remark

You can control the machine from the secure operating position only in jog mode, creep or positioning move if no other operating location is protected and no further protection is provided (e.g., finger guard bar) the movement blocks.

Unlock machine

O Press the button again twice (with an interval of max. 0.5 seconds). The LED goes out.

Safety devices

5 Guards

5.1 Fixed guards

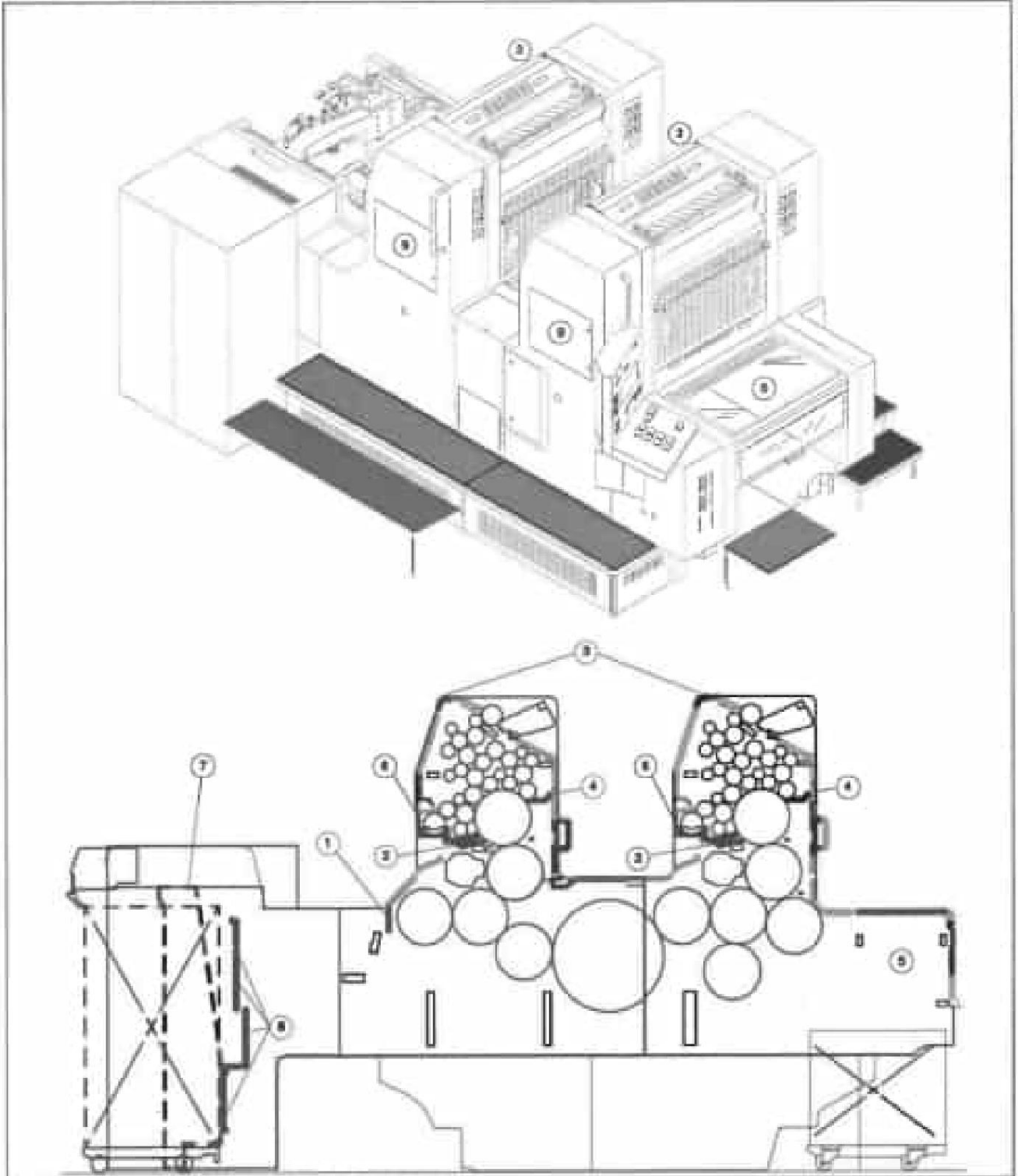

01 10000100000000000000

afb. 7

The fixed guards (fig. 7) prevent interference with rotating rollers, cylinders and the register insertion system.



Warning - risk of injury!

Only put the machine into operation when all guards are mounted and all shielding doors are properly screwed down.

The drawing (fig. 7) shows:

- shield for the input drum
- @ shielding above the blanket and pressure cylinder washing device
- @ cover above the lick roller
- ◎ shielding under the inking unit ◎
- shielding above the lay-out gripper systems
- ◎ moisture tray
- ◎ chain guards insert (2 pieces)
- @ shields in the inlay (8 pieces)
- Ⓜ screwed distribution/reverse shield door catch register adjustment (before putting into use of the machine securely)

The side walls at AZ and BZ of the inlay, of the explanations and printed matter have screwed-on coverings. Only use the machine if all guards, coverings and housing parts are mounted on the machine.

are.

Safety devices

5.2 Movable guards

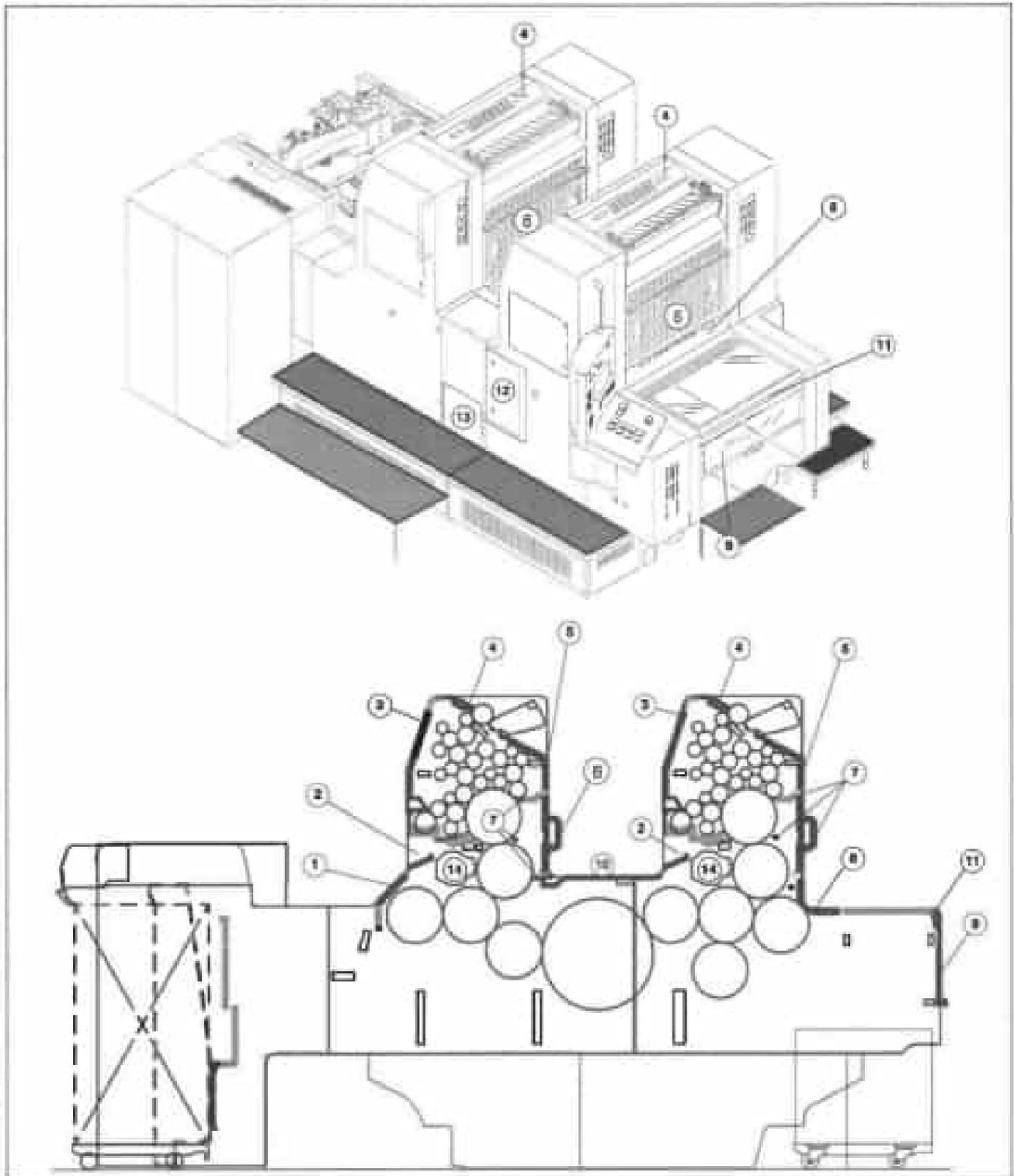

afb. 8

The movable guards (fig. 8) can be used for maintenance work must be done by hand opened.

When operating a guard at production speed, the machine immediately comes to a standstill except:

- the ink roller,
- the immersion roller and the dosing roller in the dampening system, if the damp cover (fig. 8) is not opened,
- the paint dipping roller, when the shield for the paint dipping roller and the dosing cylinder are not opened.



Warning - risk of injury!

Only put the machine into operation when all guards are mounted and all shielding doors are properly screwed down.

Afb.8	Shielding	Tip company with stroke limitation	Tip company without stroke limitation	Creep
	○ Shield above the input drum	And	-	-
	◎ Shielding for the rubber blanket and pressure cylinder washing device	And	-	-
	◎ Shielding for inking and dampening (insert side)	And	-	-
	◎ Shielding above the inking unit	And	-	-
	◎ Shielding above the distribution cylinders	-	-	-
	◎ Shielding for the plates rubber blanket cylinder (explanation side)	-	And	And
	◎ Finger shield bars ◎	-	-	-
	Shield above the number ras	And	-	-
	◎ Shielding for the lay-out gripper systems	-	-	-
	◎ Shield above pressure cylinder and transfer drums	And	-	-
	◎ Shielding between the plexiglass shields	-	-	-
Ⓛ	Screen door turning device	-	-	-
Ⓛ	Remove the shielding door from skin only	-	-	-

Safety devices

-H=ID=LB=RG-

® The washing device also serves as a shield for the rubber cloth and printing cylinder. Only use the machine when all washing equipment has been installed.

5.3 Shields on the numeroteur inkwork



afb. 9

Fig. 9 Shielding	Comments
© Shield above the inking rollers	The shield can only be opened when the numeroteur inking unit is extended. With a secured machine, tip operation with stroke limitation is possible.
© Washbasin	The sink also serves as a shield for the ink rollers. The sink must be installed in the numeroteur ink unit during operation for safety and production reasons.
© Arresteerhefboom	If the inking unit is not locked in the working position, the stop the machine immediately. This is the case with a secured machine Tip operation with stroke limitation possible.

tab. 2

Safety devices

-H-ID=LB=RG-

5.4 Guards on the high stack extension

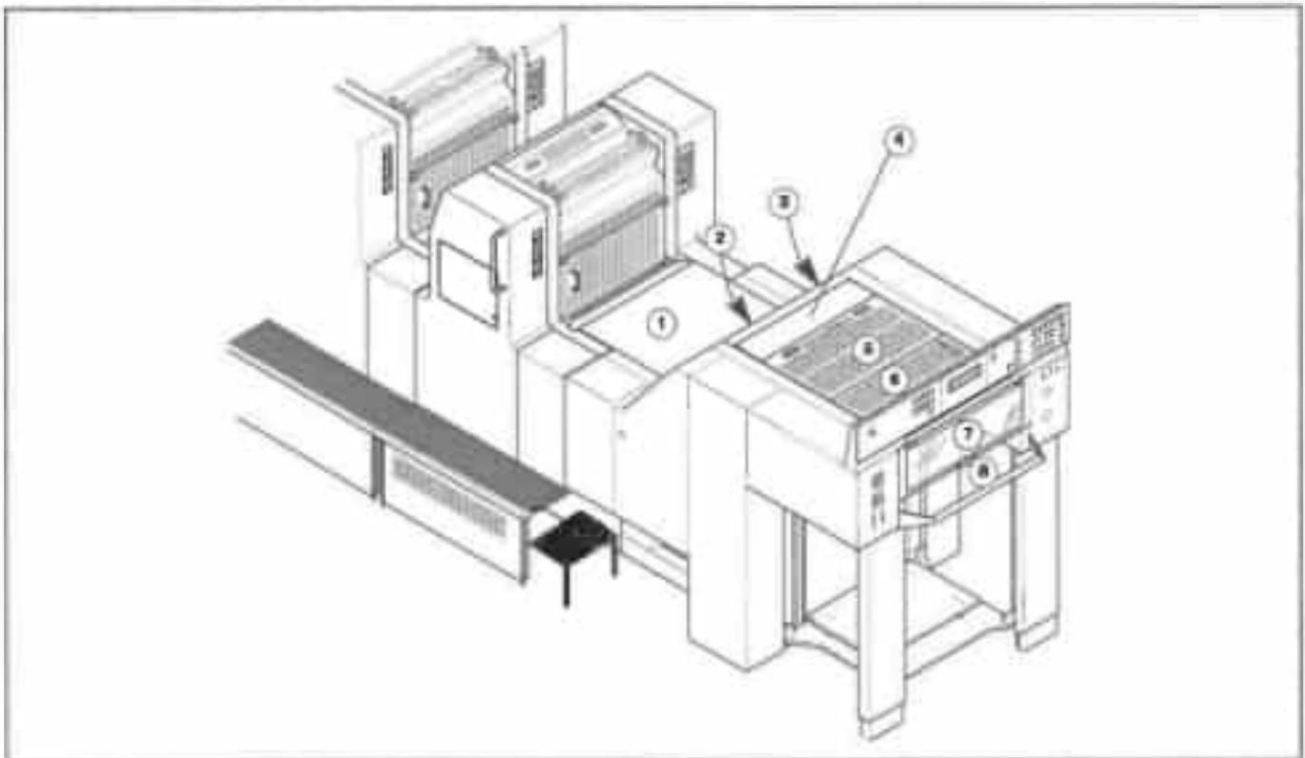

afb. 10

Fig.10 Shielding	HP company with stroke limitation	Tip company without stroke limitation	Creep
0 Shield above the transfer drum	And		
0 Shielding at the sheet entry		Fixed shielding	
0 Shielding at the auction entrance	-	With-	
© Shielding above the chain grab systems		Fixed shielding	
© Shielding above the chain grab systems			
© Guard above the delivery stack ©		Fixed shielding	
Guard above the delivery gripper systems			
© Shielding bracket for the interpretation stack		Fixed shielding	

tab. 3

5.5 Shields on the paintwork

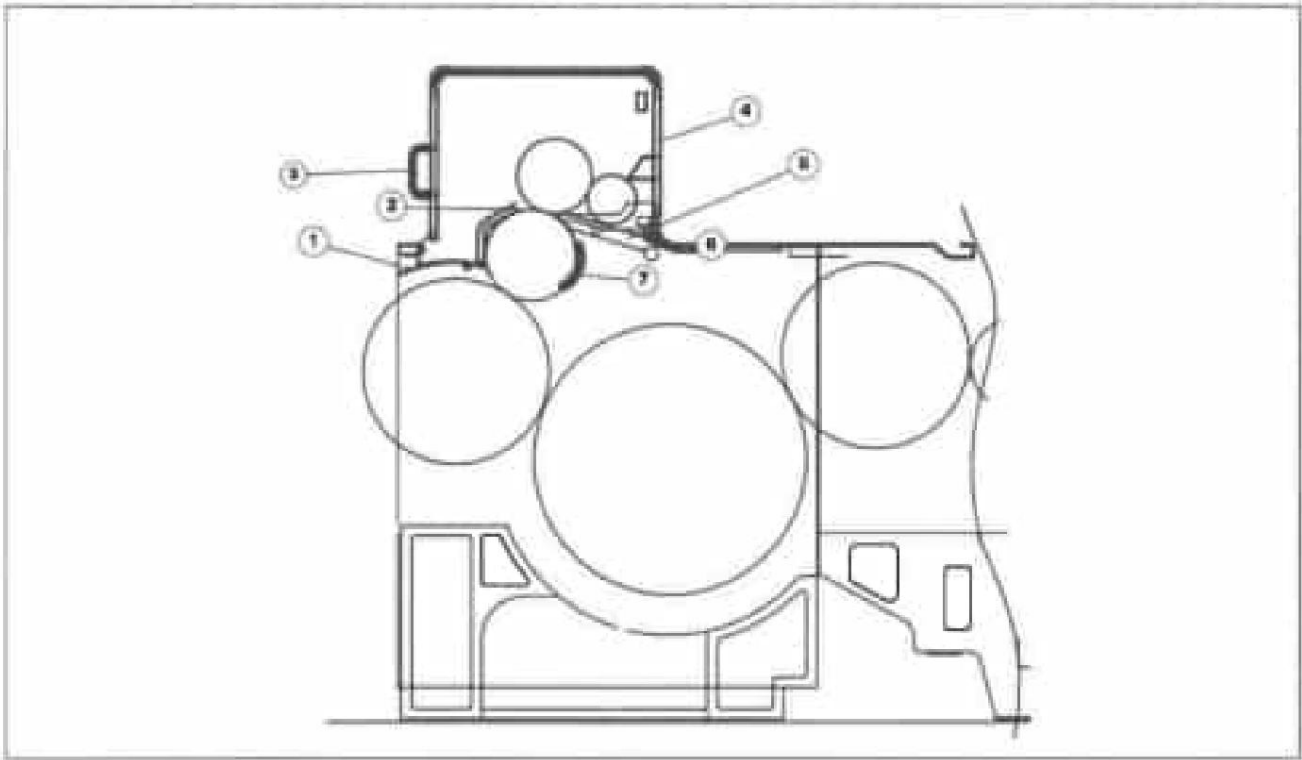

afb. 11

Fig. 11 Shielding	HP company with stroke limitation	Tip company without stroke limitation	Creep
Ⓜ Sheet guide plate above the pressure cylinder (finger shield)	.	.	.
Ⓜ Finger guard bar	.	.	.
Ⓜ Shield for dosing roller and lacquer cloth cylinder	.	And	And
Ⓜ Shielding for the paint dip roller and the dosing cylinder (insert side)	And	̄	̄
Ⓜ Shield under the paint tray Ⓜ	Fixed shielding		
Shield above the transfer drum	And	.	.
Ⓜ Channel cover on the paint-cloth cylinder	The duct cover must always be mounted	The duct cover must always be mounted	The duct cover must always be mounted

tab. 4

Safety devices

5.5 Afschermingen aan de verlengde uitleg

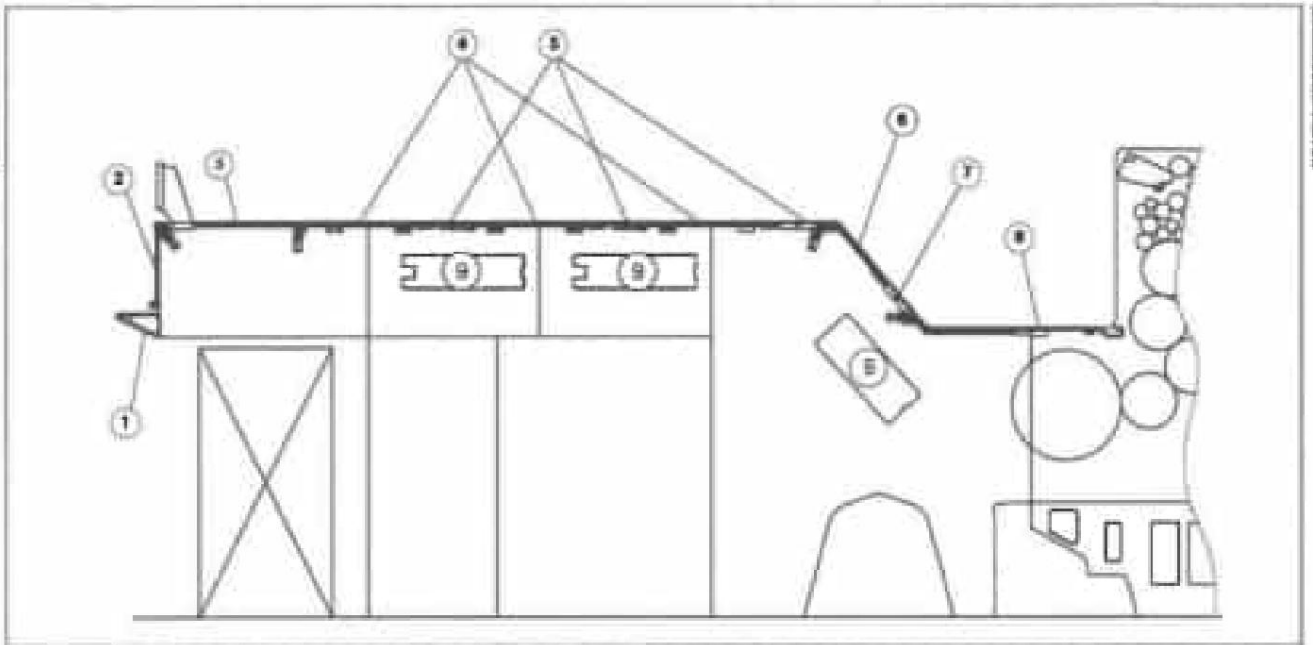

afb. 12

Fig. 12 Movable guards	Tip company with stroke limitation	Tip operation without stroke limiter	Creep
⑩ Guard for the stacking stack	-	-	-
④ Shielding above the chain grab systems	-	-	-
⑧ Shielding at the sheet entry ⑧	-	-	-
Shielding above the transfer cylinder and the explanation drum	And	-	-
⑨ Shielding for the opening of the dryer module, with the dryer removed	-	-	-

tab. 5

Fig. 12 Fixed guards
⑩ Shielding bracket for the stacking stack
⑩ Shielding above the stacking stack
④ Shielding above the chain grab systems
⑧ Shielding at the sheet entrance
⑨ Shield for the opening of the dryer module on machines without a dryer

tab. 6

5.7 Other shields

Start-up warning

When the machine is put into operation or tipped, the start-up warning (for 3 seconds) is audible after the first press of a key.

Then put the machine into operation by pressing the button again.

Limitation of the downward stroke of the stacking plate insert

When the MAIN STACK DOWN key is pressed, the stack stops 12 cm above the bottom.

Shielding bracket for the stacking stack

The shielding bracket guarantees a safety distance of 300 mm from the stacking support plate. When the MAIN STACK DOWN key is pressed, the stack stops 12 cm above the bottom.

A
—

Waarschuwing – beknellingsgevaar!

Be aware of the risk of crushing your feet. Check that nothing can become trapped under the stack before lowering the stack completely.

Safety devices

-HEIDELBERG

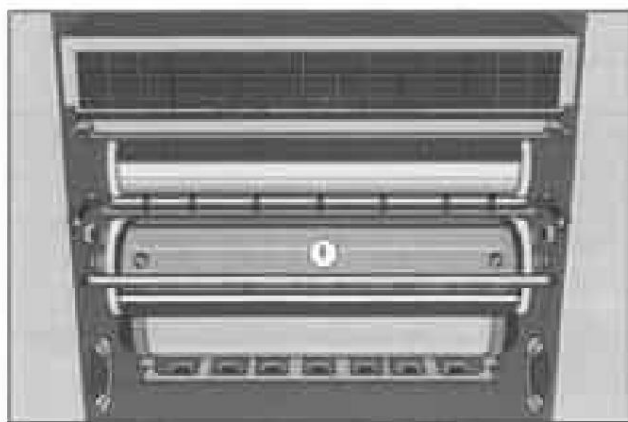

afb. 13

Channel cover

For the rubber blanket or paint cloth cylinders, there are channel covers that are mounted above the cylinder channel.



Warning - rotating rollers and cylinders!

The finger protection bars only provide sufficient protection with the channel cover in place (Fig. 13/©). Only use the machine with installed duct covers. There is a risk of serious hand injuries when operating the machine without a duct cover.

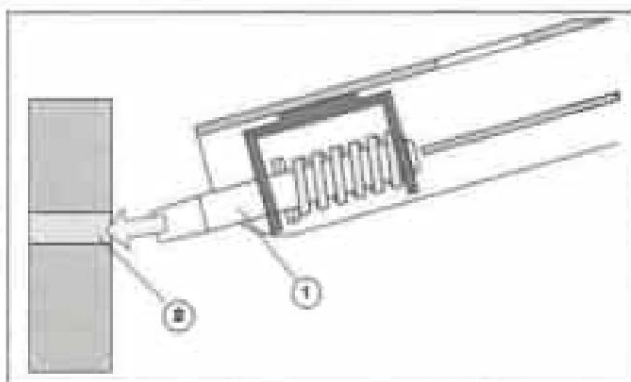

afb. 14

Installation of the duct cover

- Q When installing, start with the side on which the spring bolts (Fig. 14/©) are attached.
- O Push the spring bolts into the bores of the grease ring (Fig. 14/©).

Safety devices

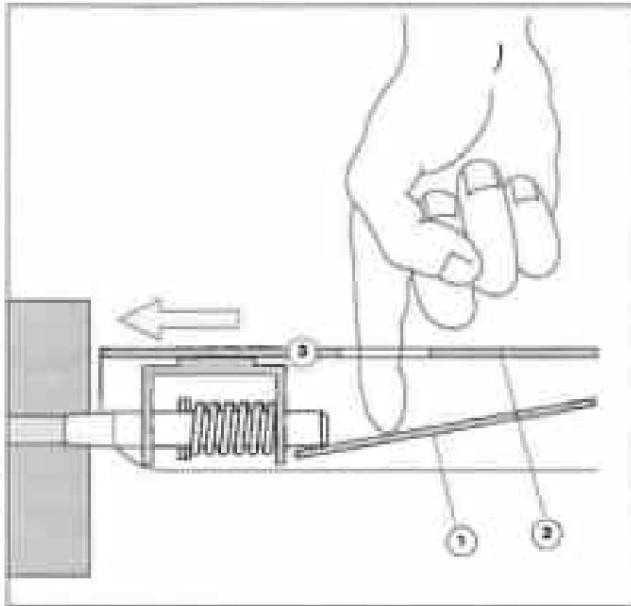

afb. 15

0 Press the leaf spring (Fig. 15/0) down and the shield (fig. 15/©) in the arrow direction move aside.

0 Push the bolts without spring (Fig. 16/0) on the opposite side into the bores in the grease ring (Fig. 16/©).

The channel cover for the paint cloth cylinder is equipped with a yellow signal dot (fig. 15/@). This channel cover is properly locked when the yellow signal point is visible.

Caution - Loose duct covers
can cause damage to the machine!
cause chine!

After installation, check whether the duct covers are properly secured.

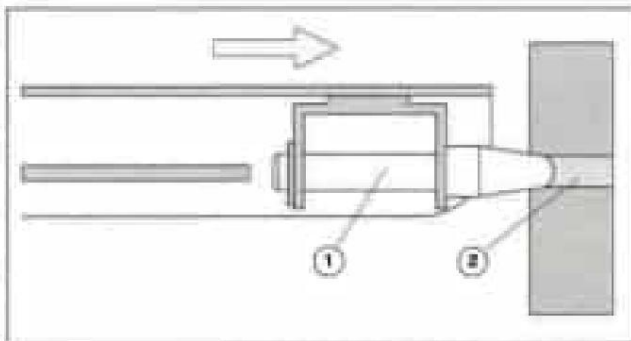

afb. 16

Disassembly of the duct cover

8 Q When disassembling, first press the leaf spring (Fig. 15/0) down. Then the duct cover - king (Fig. 15/0) ' n in the direction of the arrow and pull it out of the holes on the opposite side.

Safety devices

6 Operating modes for a secured machine

6.1 Tip operation with stroke limitation



Warning - spinning reels and cylinders!

Since the machine can operate with the guards open, there is danger due to improper operation damage.

After pressing the FORWARD or REVERSE button for the first time at the secured control location, the start-up warning is audible. Then the machine is turned on for 6 seconds tips released.

Each time you press the FORWARD or button REVERSE the rotational movement of the cylinders is released for a stroke of max. 2.5 cm. The machine is restarted for 6 seconds for it tips released.

If the machine is not running during the released time is touched, the next time you press the first, the start-up warning sounds again.

6.2 Tip operation without stroke limitation

After pressing the FORWARD or REVERSE button for the first time at the secured control location, the start-up warning is audible. Then the machine is turned on for 6 seconds tips released.

After pressing the button the second time, the cylinders as long as the FORWARD or REVERSE push button at the secured control point is pressed. The machine restarts for 6 seconds released before tipping.

If the machine is not running during the released time is touched, the next time you press the first, the start-up warning sounds again.



Warning - risk of injury!

Since in tip mode and crawl mode the machine with open guards can function, there is a risk of injury and damage if operated improperly even life-threatening.

6.3 Creep speed operation

After pressing the CRAWL key at the protected operating location, the start-up warning is activated audible. The machine is then released for 6 seconds before starting crawl mode.

After pressing the button again the machine starts at 300 rpm.

If the CRAWL key is not pressed during the released time, after the next time

When you press the button, the start-up warning will be heard again.

Stopping the machine with EMERGENCY STOP or STOP.

6.4 Positioning

After pressing the POSITION button the start-up warning is audible at the secured operating location. Then the machine is turned on for 6 seconds before starting positioning.

After pressing the button again the machine starts at 300 rpm in the position for extending/clamping the plate.

If the POSITION key is not pressed during the released time, it will be after the next time

When you press the button, the start-up warning will be heard again.

Safety devices

7 Checking the guards

7.1 Verification process

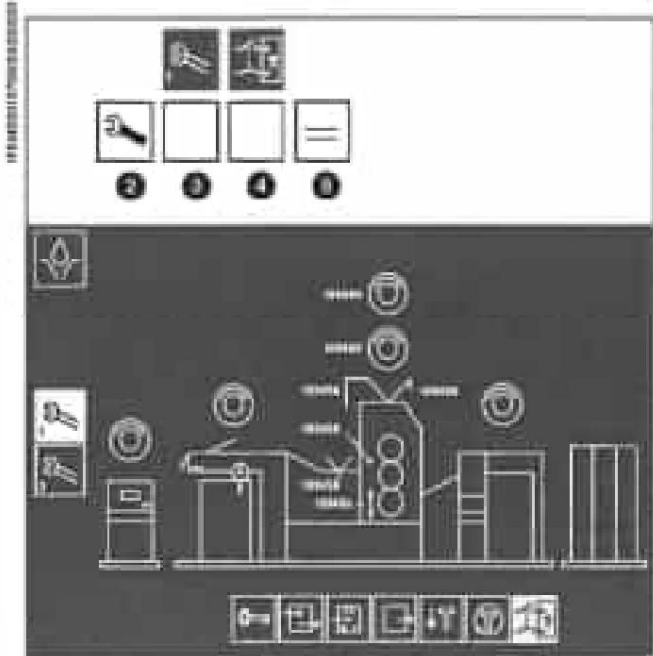

afb. 17

Only machines with central information display are equipped with this function.

- o Close all guards before checking.
Unlock all EMERGENCY STOP buttons.
- 0 PRESS THE SERVICE INSTRUCTION button
KEN: The selection menu for the service functions appears.
- 0 Select service prompt 1 using the group key was
- 0 Use the function key to select the SAFETY INFORMATION function CHECK DIRECTIONS.

An image of the will now appear in the display machine (fig. 17), in which all safety devices to be checked flash.

- 0 Press and release each EMERGENCY STOP mushroom button one after the other.
- 0 Open and close each guard one after the other ten.
- 0 Operate the finger guard bars.

With the exception of the control of the fingerprint guard bars, each guard must be opened and closed separately. If the relevant shield is functioning correctly, its symbol will be in the display goes out.

After you have operated all safety devices, Only the symbols for the overshoot control of the explanation are allowed in the CPTronic display the suction belt limit switch and for the sheet sliders flash.

- 0 With the CURRENT VALUE DISPLAY key
you can leave the SERVICE INSTRUCTIONS.

7.2 The failure symbol

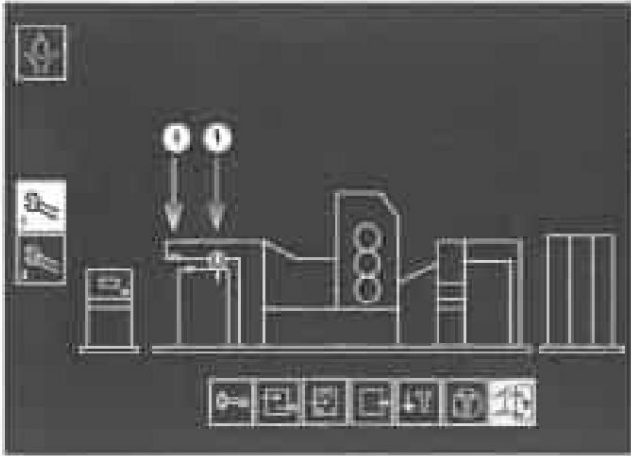

afb. 18

After checking, the display should look as shown Fig. 18 is shown. Just the symbols for it the suction belts, the lateral sheet straighteners and the sheet overflow control (Fig. 18/1) may flash.

If another symbol flashes after the check, replace the corresponding shield times to check. For shields on printing works, the number appears next to the symbol of the printing.

**Warning - risk of injury!**

If you discover that a safety device is defective, you must not operate the machine. Warn please contact the service department of your Heidelberg agent.

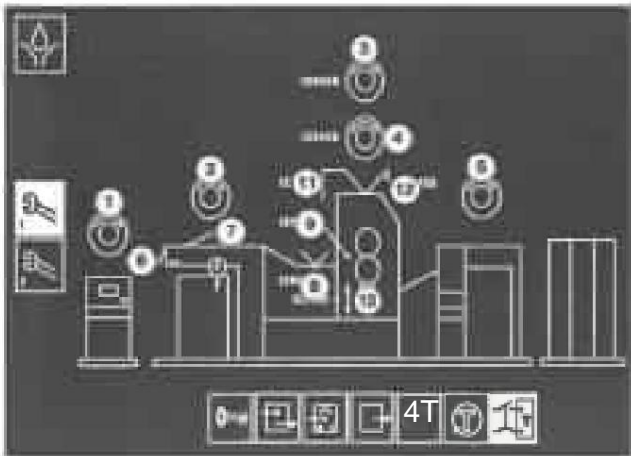

afb. 19

The symbols are shown in Fig. 19.

© EMERGENCY STOP on the control console

0 EMERGENCY OFF at the operating position of the explanation

© EMERGENCY OFF at the printing control location THE

© EMERGENCY OFF at the printing control location BZ

© EMERGENCY OFF at the operating position of the inlay

© Glass shield to the explanation

© Shielding above the grab bridges on the explanation

@ Shield above the printing cylinder / transfer cylinder

© Finger guard bar above

© Finger guard bar down

© Shielding grille for the plate cylinder (explanation side)

© Shielding grille for damp work (insert side)

Safety devices

8 Turn the machine by hand

8.1 Single color machine

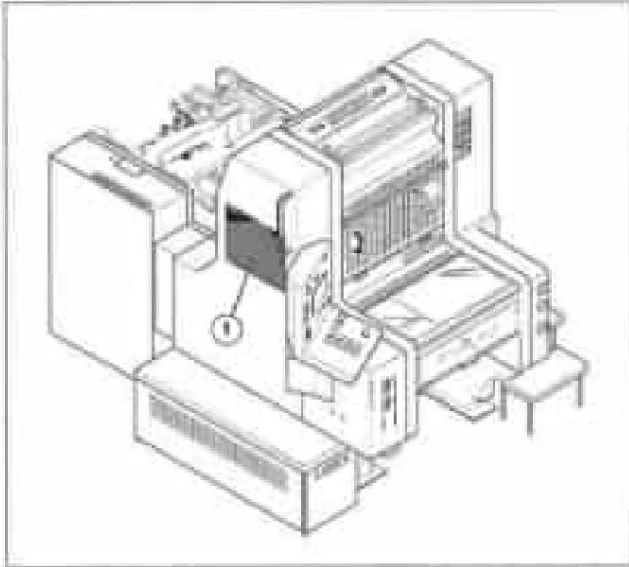

afb. 20

1 De afschermdeur (afb. 20/1) openen.

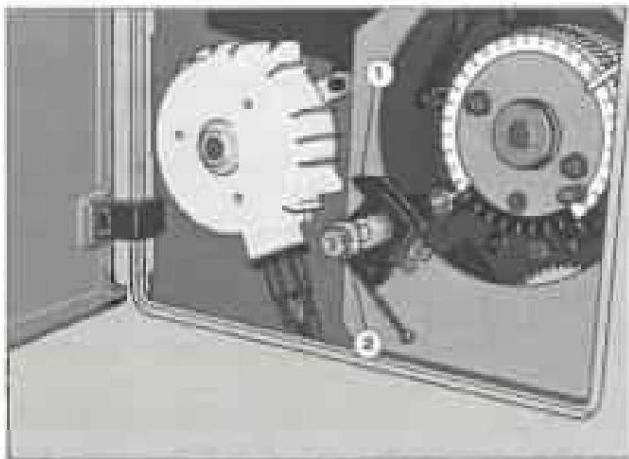

afb. 21

0 Release the locking catch (fig. 21/1).

0 Pull out the adjustment shaft (Fig. 21/2).

The machine is thus electrically protected against being put into operation and the motor brake is released when the machine is switched on.

Safety devices

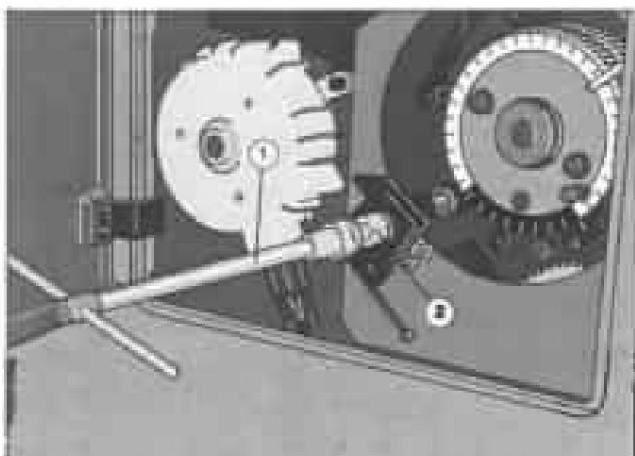

afb. 22

- Place the red T-key (Fig. 22/0) on the adjusting shaft (Fig. 22/0).

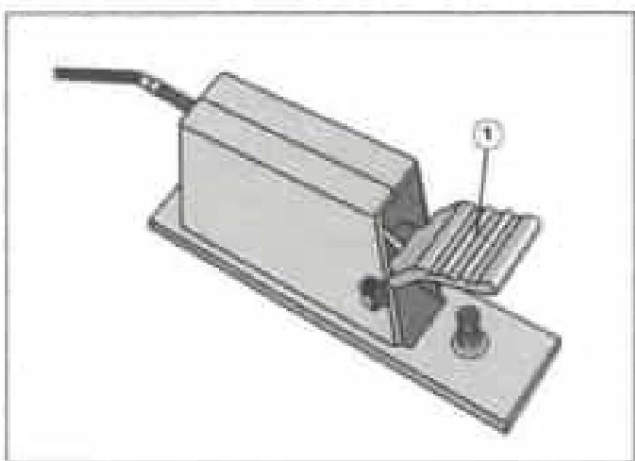

afb. 23

- **When the machine is switched on**, turn the machine by hand with the red T-key.
- **When the machine is switched off or in the event of a power failure**, press down the pedal under the step at AZ (Fig. 23/0) and **at the same time** turn the machine by hand using the red T-key.
- The machine can be turned **as long as the pedal** (Fig. 23/0) **is pressed down**.

8.2 Multi-color machine

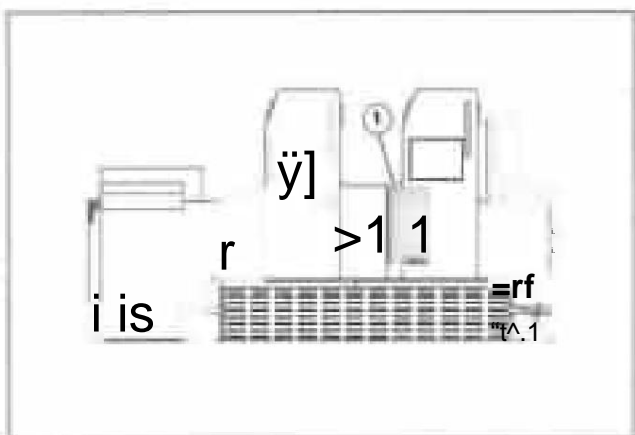

afb. 24

- Open the protective door (fig. 24/©).

Safety devices

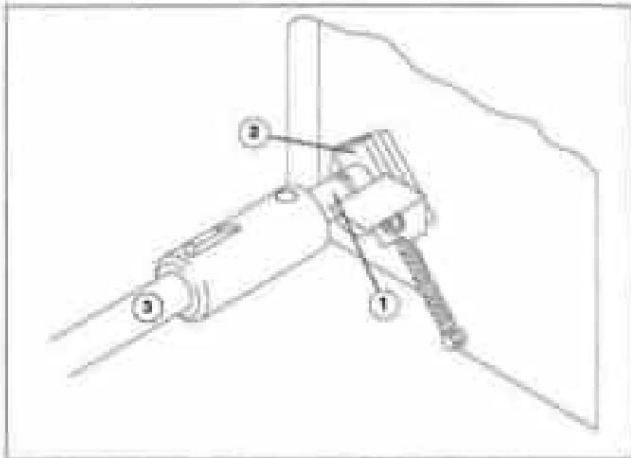

afb. 25

0 Place the T-key (Fig. 25/©) on the adjusting shaft (Fig. 25/0) and allow it to engage.

0 Release the locking catch (fig. 25/©). i 0

Press the adjusting shaft (Fig. 25/0) into the On position, do

The machine is thus electrically protected against being put into operation and the motor brake is released when the machine is switched on.

When the machine is switched on, turn the machine by hand using the red T-key (fig. 25/©).

When the machine is switched off or in the event of a power failure

Two and four color machines

0 Depress the pedal under the step at AZ (Fig. 26/©), 0 at the same time as pressing

the red T-key (Fig. 25/©) rotate the machine by hand.

As long as the pedal is pressed down, the machine can be turned.

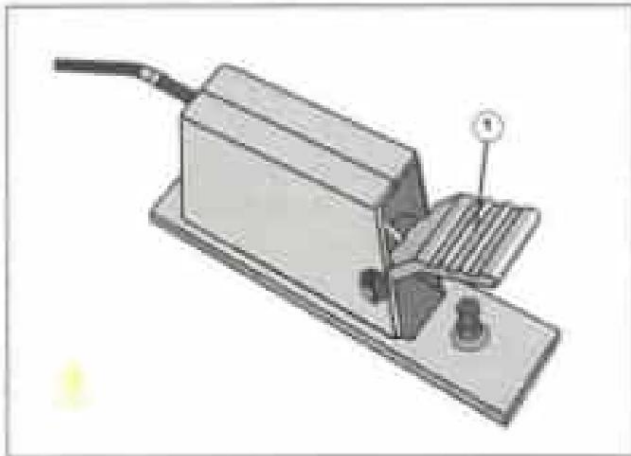

afb. 26

Machines with more than four printing units

Q Pull the bracket (Fig. 27/0) in the direction of the arrow.

0 **simultaneously** with the red T-key on the machine turn by hand.

As long as the bracket is pulled out, the machine can be rotated.

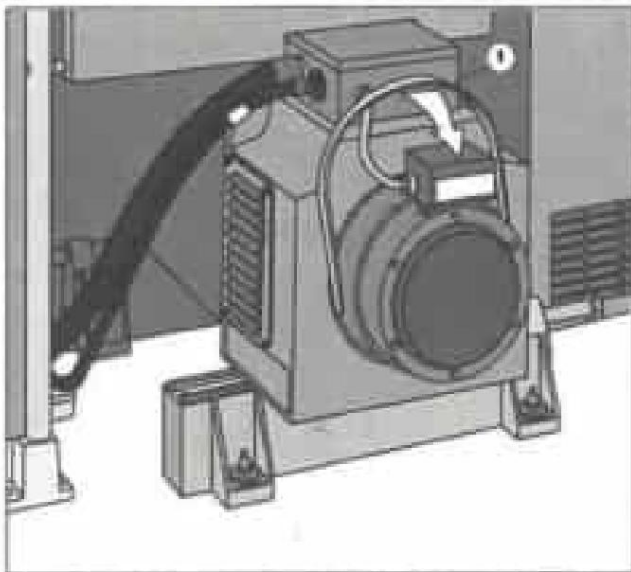

afb. 27

Direction of key rotation

- The machine rotates clockwise in reverse.
- The machine rotates counterclockwise (same direction of rotation as in production mode).

Controlling the machine

1 Control console insert	B.1.3
1.1 Overview	B.1.3
2 Printing control stations	B.1.7
2.1 BZ dampening control location	B.1.7
2.2 Operating location of printed matter AZ	B.1.7
2.3 Operating location of printed matter BZ	B.1.8
3 Paintwork control stations	B.1.9
3.1 Paintwork operating location AZ	B.1.9
3.2 Operating position paintwork explanation side BZ	B.1.10
3.3 Operating position paintwork explanation side AZ	B.1.11
4 Control console normal explanation	B.1.12
4.1 Machines with CPC, more than 2 printing works	B.1.12
4.2 Machines without CPC, SM 74-1, SM 74-2 Normal stacking layout	B.1.14
5 Control console high stack explanation	B.1.15
5.1 High stack control console explanation	B.1.15
6 Machine information display (MID)	B.1.18
6.1 Function and instructions after switching on	B.1.18
6.2 Indication of degrees, speed and faults	B.1.19
6.3 Printing speed indication and auction monitoring	B.1.19
6.4 Slanted sheet indication	B.1.20
6.5 Indication: SETTING LIMIT REACHED	B.1.20
6.6 Circulation counter indication	B.1.21
6.7 Display of the sheet monitoring 6.8 Display	B.1.22
of the baking roller speed	B.1.22
6.9 Indication of the speed of the suction belts	B.1.23
6.10 Service code indication	B.1.23
7 CPTronic control console	B.1.24
7.1 Machine met CPC	B.1.24
7.2 Machines without CPC	B.1.25
7.3 Function of the keys	B.1.25

Paragraph overview

7.4	Production image	B.1.31
7.5	Order of Service	B.1.33
7.6	Display of the operating sequence.....	B.1.34
7.7	Switching between the screen pages at the printing unit	B.1.34
7.8	Fault localization with CPTronic.....	B.1.35
7.9	The failure symbol	B.1.36

8 Explanation operating console for SM 74-1, SM 74-2 with normal stacking extension without CPC**B.1.41**

8.1	Overview	B.1.41
8.2	Explanation control console - machine keys	B.1.42

9 Input at machines with KID**B.1.50**

9.1	General comments regarding the image	B.1.50
9.2	Assignment selection	B.1.50
9.3	Entering numerical values	B.1.51
9.4	Changing and saving order data	B.1.52
9.5	Transfer saved job to machine	B.1.53
9.6	Group keys/function keys	B.1.54
9.7	Production image	B.1.55
9.8	Fault localization	B.1.56
9.9	Storingssymbolen - storing machine	B.1.57
9.10	Fault symbols - production fault .	B.1.60

10 Cleaning the operating positions**B.1.62**

10.1	Cleaning agents	B.1.62
------	-----------------------	--------

1 Control console insert

1.1 Overview

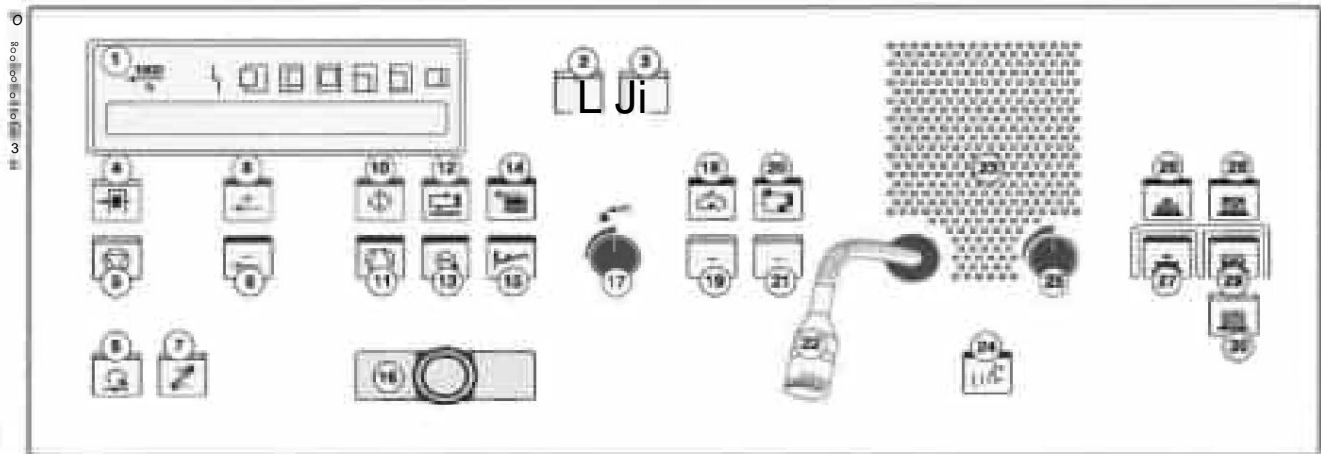

Fig. 1 Control console insert

© Machine information display (MID)

Display of the current machine data (print number, speed), control of the sheet feed, notification of general functional faults.

© FAILURE DETECTOR-red

LED lights up: The machine cannot be put into operation due to a fault.

© FAILURE MELDER-blue

LED flashes: Fault in the insert console.

© PRODUCTION

Condition: Machine in operation. - Service: All selected functions are activated, e.g. moisture and ink rollers on the plate, ink lick roller on, compressor on, sheet feed on. The printing works automatically pressurize. - When the button is pressed again, the machine goes to the pre-selected speed. Dmv the SLOW key can increase the amount interrupted.

© STOP

Operation: Stops the machine. - Operation during production: The input is stopped, all printed matter is switched off at pressure, the sheets are transported to the delivery, the machine stands still, the compressor is switched off.

Controlling the machine

-HEIDELBERG-

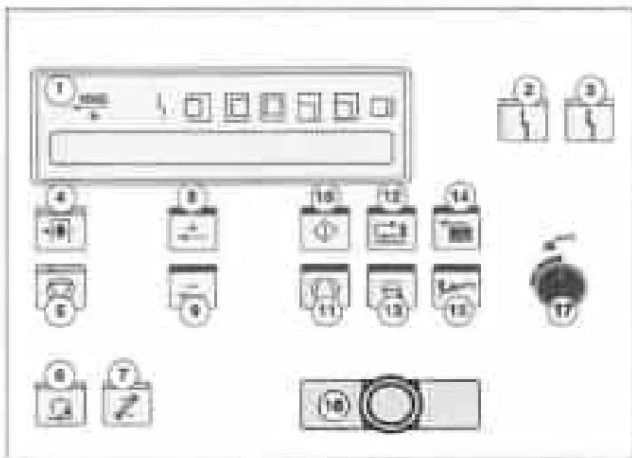

afb. 2 Bedieningsconsole inleg, linkergedeelte

© FORWARD

Prerequisite: The PROTECT button on the insert is pressed. Operation: The start-up warning is audible, renewed operation: the machine runs forward as long as the button is pressed.

© SECURE

To protect: Press the key twice. LED lights up. The machine can only be moved in tip mode with or without stroke limitation. To unlock: Press the button twice.

© FAST

Operation: Increases the speed of the machine steplessly as long as the button is pressed.

© SLOW

Operation: Reduces the speed steplessly as long as the button is pressed. Interrupts the ramping of the machine.

Ⓜ

OPERATION Operation: The start-up warning is audible. After pressing the button again, the machine starts at minimum speed.

© COMPRESSOR

Operation: Switching on (LED lights up) and switching off the compressor.

© INSERT

Operation: Automatic switching on (LED lights up) and switching off of the insert.

Ⓜ MOISTURE ROLLS ON/

OFF Condition: Machine in operation. - Operation: Switch on (LED lights up) resp. shutting down all pre-selected damp works.

Ⓜ PAPER FLOW

Operation: Switch on (LED lights up) and switch off the paper feed.

Controlling the machine

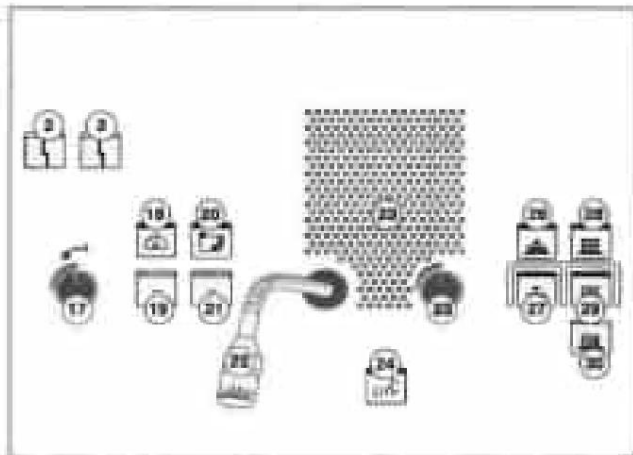

Fig. 3 Control console insert, right part

- 17** RELEASE STOP FINGERS

Operation: The stop fingers are released. Remove the retained sheet from the insert table.
- 18** MUSHROOM PUSH EMERGENCY STOP

Operation: The machine is immediately stopped and the mushroom push button is locked.

- Turn: The lock is opened.
- 19** APPLY BLOWING AIR

Adjusting the amount of blowing air from the sheet holders at the front.
- 18** VACUUM SUCTION BELTS +

Operation: Increasing the vacuum flow rate on the suction belts. First the value is increased in 1% steps, and with a longer key press in 5% steps. The vacuum flow rate is displayed graphically and in % on the MID.
- 19** VACUUM SUCTION BELTS

Operation: Reducing the vacuum flow rate at the suction belts. First the value is reduced in 1% steps, and with a longer key press in 5% steps. The vacuum flow rate is displayed graphically and in % on the MID.
- 20** BLOW AIR COMPENSATION + For machines from 5 presses: Greater blow air compensation or adjust the amount of blowing air.
- 21** BLOW AIR COMPENSATION - For machines from 5 presses: Smaller blow air compensation or adjust the amount of blowing air.
- 22** MICROPHONE
- 23** SPEAKER
- 24** INTERCOM SYSTEM

Enable and disable the intercom system.
- 25** VOLUME CONTROL

Rotary knob for adjusting the speaker volume.

Controlling the machine

Fig. 4 Control console insert, right part

@ ASSISTANT STACK UP

Operation: The auxiliary stack moves upwards, first slowly, then quickly. Start of the semi-automatic non-stop stack change.

@ ASSISTANT STACK DOWN

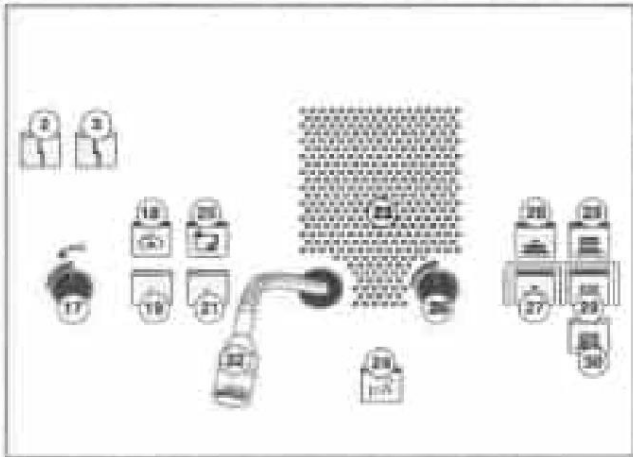
The AUXILIARY STACK DOWN button is indicated by a raised edge strip. - Service: The auxiliary stack moves down, first slowly, then quickly.

@ MAIN STACK UP

Operation: The insert stack moves upwards, first slowly, then quickly. Shortly before the tactile foot is reached, the automatic stacking control takes over the transport.

@ MAIN STACK DOWN

The MAIN STACK DOWN key is by a raised edge frame. - Operation: The insert stack automatically moves down, first slowly, then quickly. - Interrupt with the STACK STOP key. The downward movement ends 12 cm above the bottom. By pressing the button again, the stacking plate or stacking table is placed on the bottom laid out.

@ STACK STOP - red

Operation: Stop the stacking movement of auxiliary and main pile.

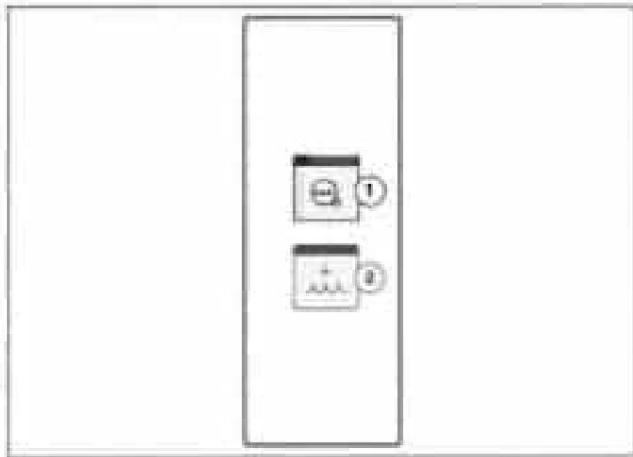
2 Printing control stations**2.1 Bedieningsplaats vochtwerk BZ**

afb. 5

① TURN ON MOISTURE ROLLERS

Operation: The moisture transfer and dosing roller are turned on, the immersion roller does not turn. - In this position, the moisture rollers can be adjusted.

② WASHING MOISTURE ROLLERS

Operation with open protective grille: The immersion roller and the dosing roller rotate at washing speed. - Operation during operation: Extra moisture.

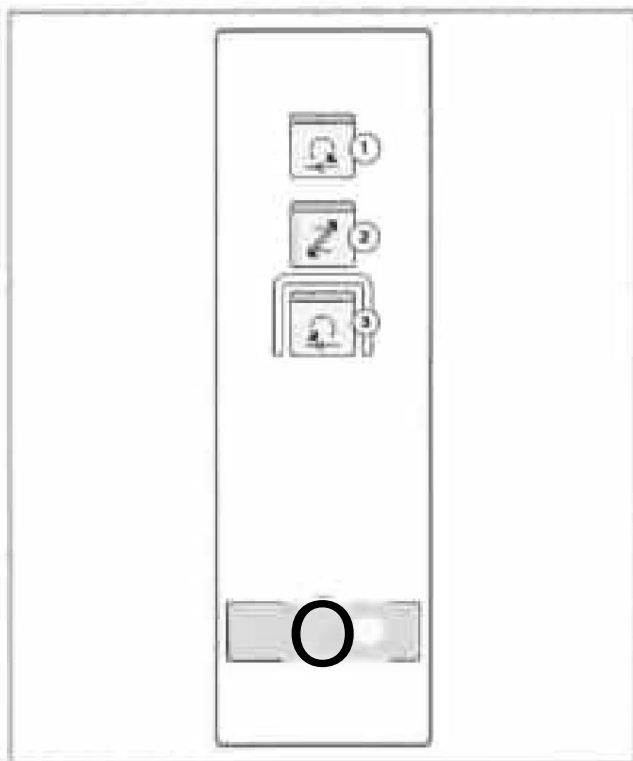
2.2 Printing service location AZ

afb. 6

OH FORWARD

Prerequisite: The PROTECT key on the printing has been done. Operation: The start-up warning is audible, again operation: the machine runs forward as long as the button is pressed.

© SECURE

To protect: Press the button twice. LED burns. The machine can only be operated in tip mode can be moved with or without stroke limitation. To unlock: Press the button twice.

© REVERSE

The REVERSE key is raised edge list made known. - Condition: The the PROTECT button on the printed matter has been pressed. Operation: The start-up warning is audible, restart operation: the machine rotates backwards as long as the button is pressed.

© MUSHROOM PUSH EMERGENCY STOP

Operation: The machine is immediately stopped and the mushroom pusher is locked. - Turn: The lock is opened.

Controlling the machine

-HEIDELBERG-

2.3 BZ printing service location

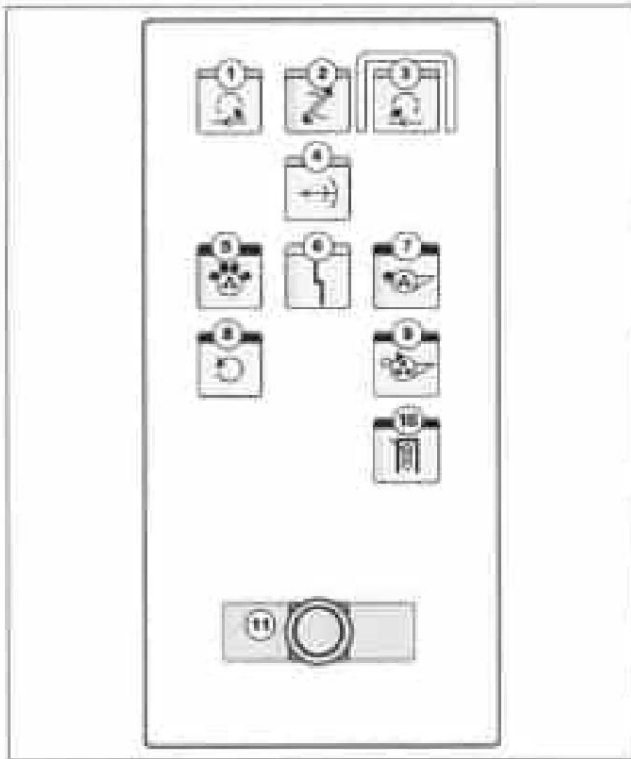

afb. 7

- ① **FORWARD**
Operation: The PROTECT button on the printed matter has been operated. Operation: The start-up warning is audible, restart operation: the machine runs forward as long as the key is pressed pressed.
- Ⓞ **TO SECURE**
To protect: Press the button twice. LED burns. The machine can only be operated in tip mode can be moved with or without stroke limitation. To unlock: Press the button twice.
- ③ **BACKWARDS**
The REVERSE key is raised edge list made known. - Condition: The the PROTECT button on the printed matter has been pressed. - Operation: The start-up warning is audible, renewed operation: the machine rotates backwards as long as the button is pressed.
- Ⓞ **CRAWL**
Prerequisite: The PROTECT key on the printing has been done. Operation: The start-up warning is audible, when operated again: the machine rotates at approx. 5 rpm.
- Ⓞ **INK ROLLS ON/OFF**
Operation: Switch on (LED lights up) or switch off of the ink rollers in the relevant printed matter.
- Ⓞ **FAILURE INDICATOR - blue**
LED flashes: Printing fault.
- Ⓞ **LICROLL ON/OFF**
Operation: Switch on (LED lights up) and switch off of the lick roller in the relevant printed matter.
- Ⓞ **POSITIONING**
Operation: The start-up warning is audible. The machine runs at crawl speed; the plate cylinder of the printed matter in question rotates the plate clamping position; the machine is stopped. - Prerequisite: The PROTECT key the printing work has been done.
- Ⓞ **ROTATE INK ROLLER**
Operation: The ink tank roller rotates at washing speed.
- Ⓞ **PLATE EFFORT**
Operation: The printing unit switches to pressure with the retracting plate.
- Ⓞ **MUSHROOM PUSH EMERGENCY STOP**
Operation: The machine is immediately stopped and the mushroom pusher is locked. - Turn: The lock is opened.

3 paintwork control stations

3.1 Bedieningsplaats lakwerk AZ

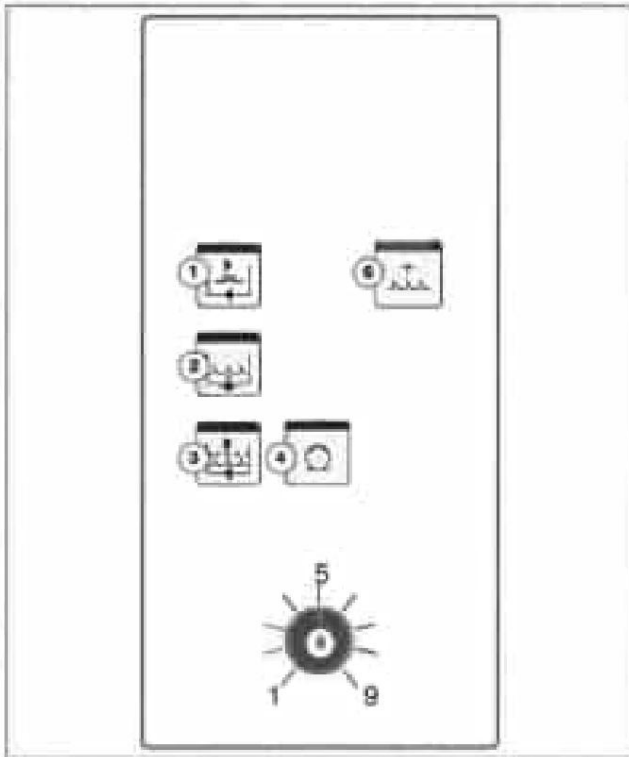

afb. 8

| © CIRCULATE PAINT

| Operation: If nothing has been selected in advance
| was - switch (LED on) to paint circuit
| butts

| Operation: EMPTY PAINT TRAY if in advance
i was selected - switching off the paint pump.

© LAKBAK THE DOCTOR

Operation: If in advance PAINT CIRCULATION
was selected - button © flashes, button ©
lights up - the paint is pumped out.

Operation: If RINSE was previously selected - button
@ flashes, button © lights up -
the flushing agent is pumped out.

@ TO RINSE

Operation: Switching (LED on) of the
paint supply device to the rinse aid circuit. Can only
be selected if
EMPTY PAINT TRAY was selected first.

© PAINT PUMP ON/OFF

Operation: Switching on the paint pump (LED
lights up). Switching on is only possible if PAINT
CIRCULATE, EMPTY PAINT TRAY or
RINSING was selected. - Re-operation: Switch off
the paint pump.

@ PAINT PUMP OUTPUT CONTROLLER

Turn clockwise: increase yield.

Turn counterclockwise: reduce yield.

© TURN THE IMMERSION ROLLER

The paint dip roller rotates for cleaning as long as the
key is pressed.

Controlling the machine

3.2 Operating position paintwork explanation side BZ

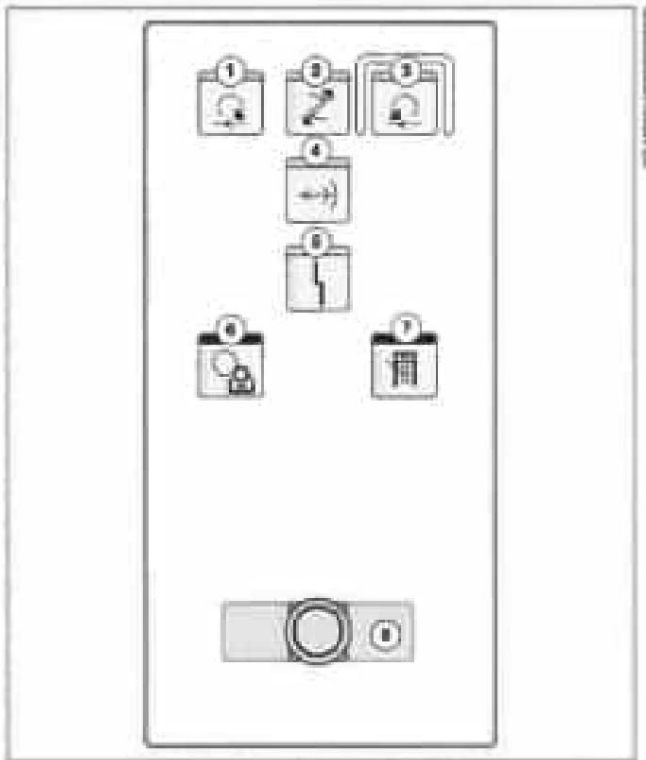

afb. 9

- © FORWARD
Prerequisite: The PROTECT button on the paintwork has been pressed.
Operation: The start-up warning is audible, re-operation: the machine runs forward as long as the button is pressed.
- © PROTECT To protect: Press the button twice. LED lights up. The machine can only be moved in tip mode with or without stroke limitation. - Unlock: Press the button twice.
- © REVERSE The REVERSE button is identified by a raised edge strip. - Prerequisite: The PROTECT button on the paintwork has been pressed.
Operation: The start-up warning is audible, re-operation: the machine runs backwards as long as the button is pressed.
- © CRAWLING
Prerequisite: The PROTECT key on the last DW has been pressed. Operation: The start-up warning is audible, when operated again: the machine rotates at approx. 5 rpm.
- © FAILURE DETECTOR - blue LED
flashes: fault in the paintwork.
- © STOP IMMERSION ROLLER
Operation: Stop the immersion roller and the dosing roller.
- © APPLY PAINT CLOTH
Operation: The paintwork switches to pressure with the incoming plate.
- © MUSHROOM PUSH EMERGENCY STOP
Operation: The machine is immediately stopped and the mushroom push button is locked.
Turn: The lock opens.

3.3 Operating position paintwork explanation side AZ

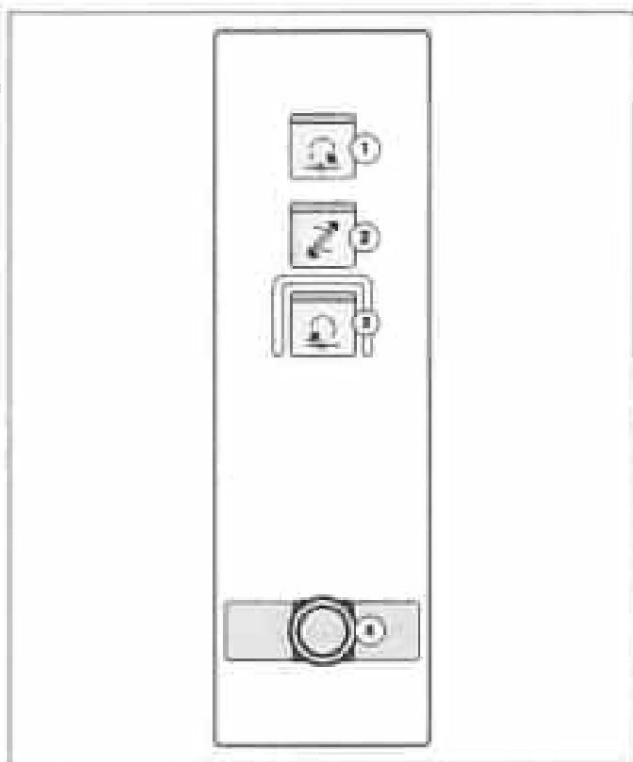

afb. 10

© FORWARD

Prerequisite: The PROTECT key on the paintwork has been serviced. Operation: The start-up warning is audible, again operation: the machine runs forward as long as the button is pressed.

© SECURE

To protect: Press the button twice. LED burns. The machine can only be operated in tip mode can be moved with or without stroke limitation. - Unlock: Press the button twice.

© REVERSE

The REVERSE key is raised edge list made known. - Condition: The The PROTECT button on the paintwork has been pressed. Operation: The start-up warning is audible, restarting the machine: the machine is running backwards as long as the button is pressed.

© MUSHROOM PUSH EMERGENCY STOP

Operation: The machine is immediately stopped and the mushroom pusher is locked. - Turn: The lock is opened.

Controlling the machine

4 Control console normal explanation

4.1 Machines with CPC, more than 2 printing works

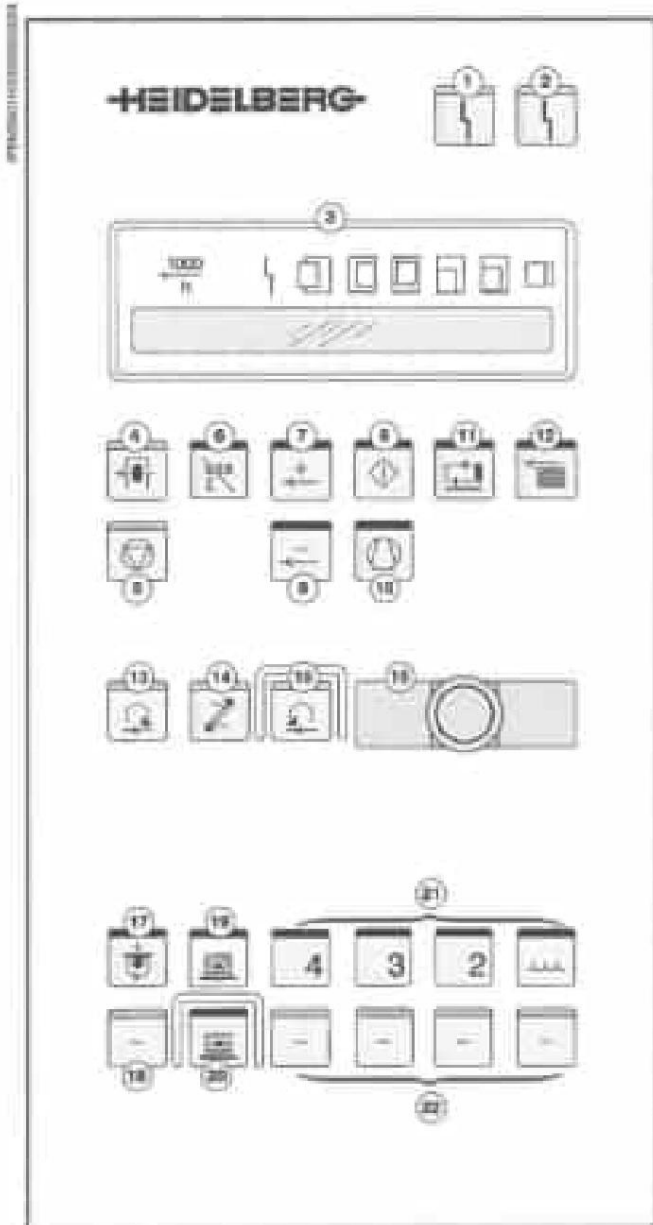

afb. 11 Machines met CPC

- ⊙ FAILURE INDICATOR - red
LED lights up: The machine cannot be put into operation due to a fault.
- ⊙ FAILURE INDICATOR - blue
LED flashes: Fault in the explanation console.
- ⊙ MACHINE INFORMATION DISPLAY (MID)
Display of the current machine data (printing speed, degrees), control of the auction supply, reporting of general functional faults.
- ⊙ PRODUCTION
Operation: All selected dampening works are placed on the plate for preliminary dampening. The compressor is switched on, the paper supply starts; the machine automatically pressurizes. -
Condition: Machine in operation.
When the button is pressed again, the machine goes to the preselected speed. - The SLOW button interrupts the ramp.
- ⊙ STOP
Control: Stops the machine.
- Operation during production: The loading is stopped, all printing units are simultaneously switched off at pressure, the sheets are transported to the delivery area, the machine stands still, the compressor is switched off.
- ⊙ CIRCULATION
COUNTER Operation: Switching on (LED lights up) and switching off the circulation counter.
- ⊙ FAST
Operation: Steplessly increases the speed of the machine.
- ⊙ SLOW
Operation: Reduces speed steplessly.
Interrupts the machine's ramp-up.

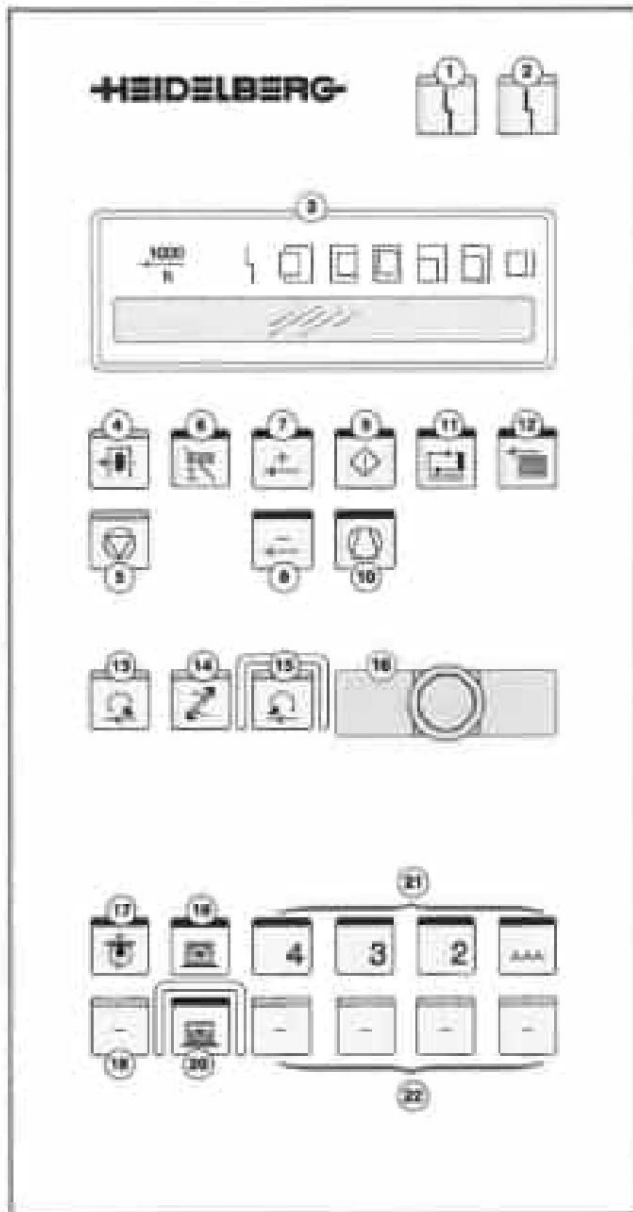

afb. 12

- ⑧ COMPANY
Operation: The start-up warning is audible. - When operated again, the machine rotates at 3000 rpm.
- ⑧ COMPRESSOR
Operation: Switching on (LED lights up) and switching off the compressor.
- ⑧ INPUT
Operation: Switching on (LED lights up) and switching off the insert.
- ⑧ PAPER RUN
Operation: Switching on (LED lights up) and switching off the paper flow.
- ⑧ FORWARD
Prerequisite: Press the PROTECT button on the leg control console is operated. Service: The start-up warning is audible, restarted operation: the machine runs forward as long as the key is pressed.
- ⑧ TO SECURE
To protect: Press the button twice. LED burns. The machine can only be operated in tip mode can be moved with or without stroke limitation. - Unlock: Press the button twice.
- ⑧ BACKWARDS
The REVERSE key is raised edge list made known. - Condition: The The PROTECT button on the explanation control console has been pressed. - Operation: The start-up warning is audible, again operation: the machine runs backwards as long as the key is pressed.
- ⑧ EMERGENCY OUT
Operation: The machine is immediately stopped and the mushroom pusher is locked.
- Turn: The lock is opened.

Controlling the machine

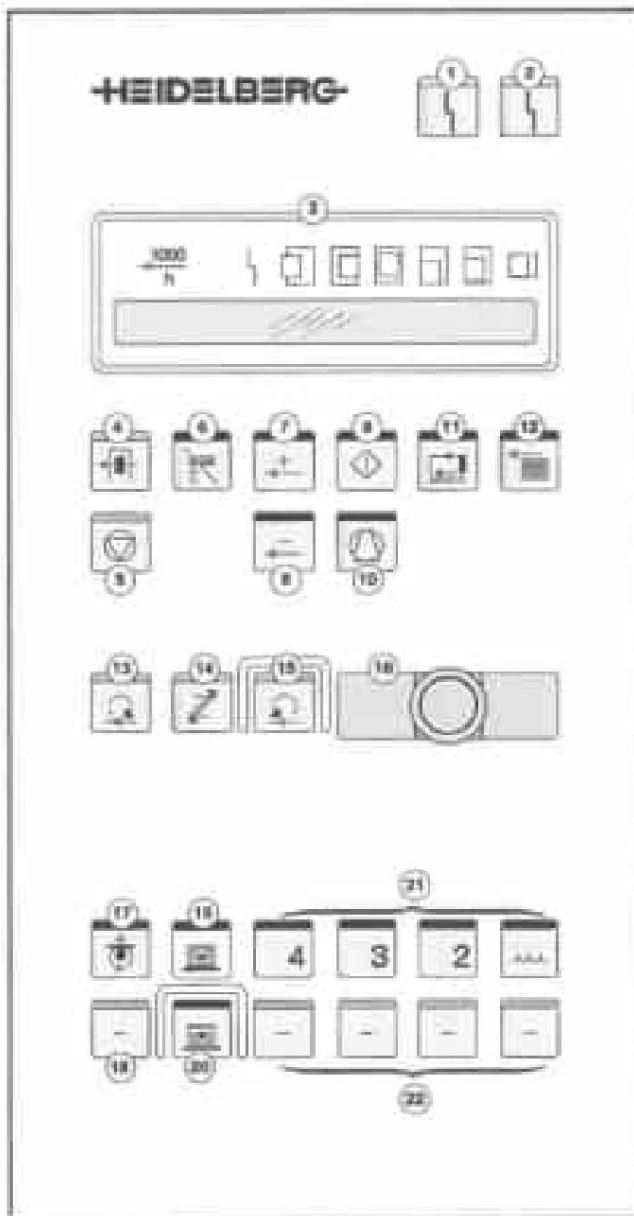
-HEIDELBERG-

afb. 13

4.2 Machines without CPC, SM 74-1, SM 74-2 Normal stacking layout

- ⑩ SUCTION BELTS
FAST Operation: Increase the speed of the suction belts in 2% steps; indication in the MID.
- ⑪ SUCTION BELTS SLOW
Operation: Reduce the speed of the suction belts in 2% steps; indication in the MID.
- ⑫ MAIN STACK UP
Operation: The stack stack moves up.
- ⑬ MAIN STACK DOWN
The MAIN STACK DOWN button is indicated by a raised edge frame. - Operation: The stack stack moves down.
- ⑭ HUMIDITY +
Operation: Extra moisture in the relevant dampening system. The baking roller speed is increased by 2% each time the button is pressed. The speed is displayed in percent in the MID.
- ⑮ HUMIDITY -
Operation: The baking roller speed in the selected moisture unit decreases by 2% with each press of the button. The speed is displayed in percent in the MID.

Description see chapter "Explanation operating console for SM 74-1, SM 74-2 with normal stacking extension without CPC"

5 Control console high stack explanation

5.1 High stack control console explanation

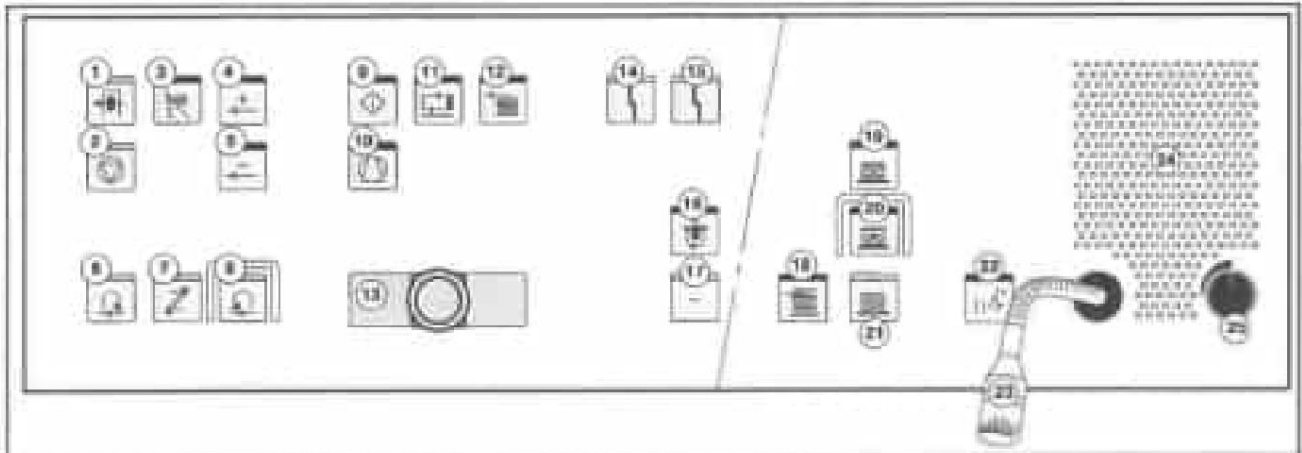

afb. 14

0 PRODUCTION

Operation: All selected dampening works are activated the plate for pre-moisture. The compressor is turned on, the paper feed starts; the machine automatically pressurizes. - Condition: Machine in operation. When the button is pressed again, the machine switches to the preselected speed. - The SLOW-SLOW button interrupts the ramp.

@ STOP

Operation: Stops the machine. - Operation during production: The input is stopped, all Printing units are simultaneously switched off at pressure, the sheets are transported to the delivery area, the machine stands still, the compressor is switched off.



Fig. 15 Control console high stack explanation, left part

§ @ EDITION COUNTER

| Operation: Switching on (LED lights up) and switching off the circulation counter.

| © FAST

§ Controls: Controls the speed of the machine stepless.

© SLOW

Operation: Reduces the speed steplessly. Interrupts the machine's ramp-up.

© FORWARD

Prerequisite: The PROTECT button on the explanation has been pressed.

- Operation: The start-up warning is audible, the machine runs forward.

Controlling the machine

-H=ID=LB=RG-

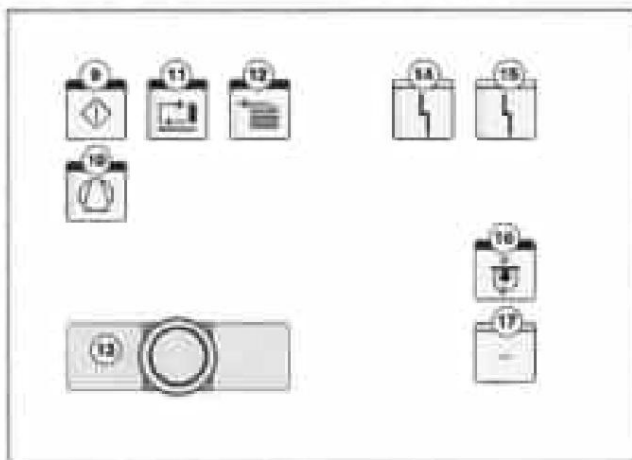

afb. 15 Bedieningsconsole hoge stapel-uitleg, middelste gedeelte

© SECURE

To protect: Press the button twice. LED burns. The machine can only be operated in tip mode can be moved with or without stroke limitation. - Unlock: Press the button twice.

© REVERSE

The REVERSE key is increased by 3 edge lists made known. - Condition: The The PROTECT button on the explanation control console has been pressed. - Operation: The start-up warning is audible, again operation: the machine runs backwards as long as the key is pressed.

© COMPANY

Operation: The start-up warning is audible. - When operated again, the machine rotates at 3000 rpm.

© COMPRESSOR

Operation: Switching on (LED lights up) and switching off the compressor.

© INVESTMENT

Operation: Switching on (LED lights up) and switching off the insert.

© PAPERLOOP

Operation: Switching on (LED lights up) and switching off the paper flow.

© EMERGENCY OFF

Operation: The machine is immediately stopped and the mushroom pusher is locked. - Turn: the lock is opened.

© FAILURE INDICATOR-red

LED lights up: The machine cannot be put into operation due to a fault.

© FAILURE INDICATOR-blue

LED flashes: Fault in the explanation console.

© SUCTION BELTS FAST

Operation: Increase the speed of the suction belts in 2% steps; clue in the MID.

© SUCTION BELTS SLOWLY

Operation: Reduce the speed of the suction belts in 2% steps; clue in the MID.

Controlling the machine

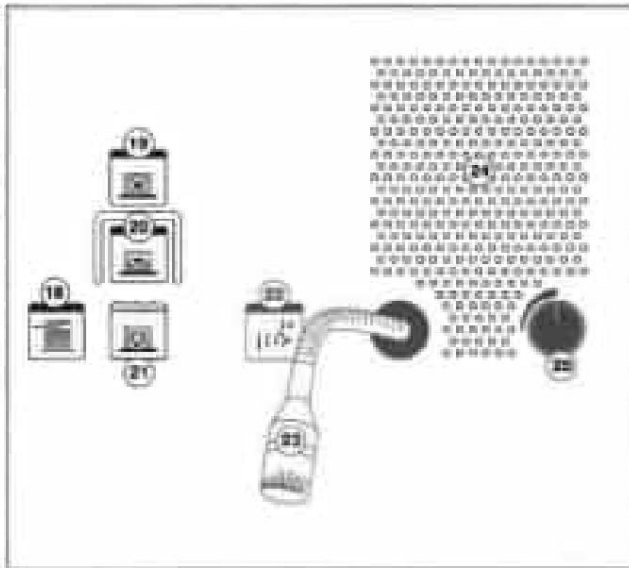

afb. 17 Bedieningsconsole hoge stapel-uitleg, rechter gedeelte

- Ⓜ SHELL CATCHERS
- Ⓜ MAIN STACK UP
Operation: The stack stack moves up.
- Ⓜ MAIN STACK DOWN
The key is identified by 3 raised edge frames.
- Operation: The stacking stack moves down.
- Ⓜ STACK STOP - red
Operation: Stops the movement of the main stack stack.
- Ⓜ INTERCOM SYSTEM ON/OFF
- Ⓜ MICROPHONE ON/OFF
- Ⓜ SPEAKER ON/OFF
- Ⓜ VOLUME CONTROL

Controlling the machine

6 Machine information display (MID)

6.1 Function and instructions after switching on

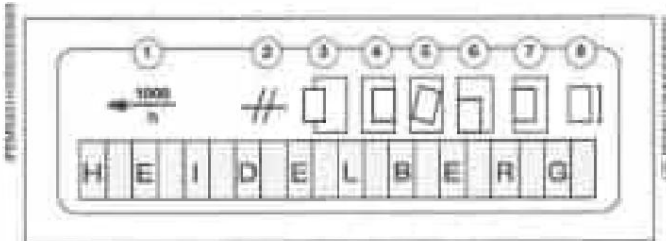
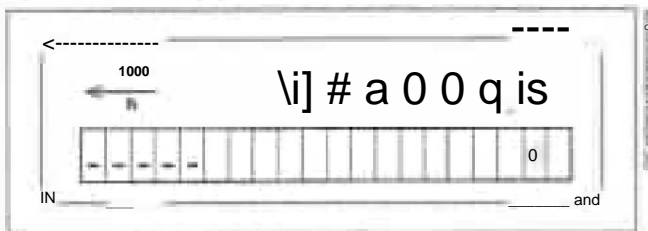

Fig. 18 MID overview

The self-test is started by switching on the machine at the control box. The text HEIDELBERG appears in the display (fig. 18).

- © Indication of printing speed/degrees
- @ Fault indication
- @ Early and leftover sheet
- 0 Leave skin
- © Slanted sheet
- © Velinlooperror
- 0 Trackout
- © Double sheet



afb. 19

After the self-test has been completed successfully, lines will appear in the pressure speed/degree display (Fig. 19). The stripes extinguish after one cylinder revolution.

The pre-selected edition (here 0) is indicated on the right in the MID.

6.2 Indication of degrees, speed and faults



afb. 20 Indication of degrees, speed and disturbances

After one cylinder revolution, the MID displays the number angular degrees of the instantaneous cylinder position (here 180.5°, Fig. 20).

The MID states the number of **angle degrees**

- when the machine is at a standstill
- during positioning, crawl speed, tip operation.

The MID states the **speed**

- in operation

In the **fault indication** (Fig. 20/©) a fault the position identification number of the unit in which the fault occurs (here 11). Meaning of the position identification numbers:

Position identification number	Meaning
1-8	printing 1-8/lacquer work
11	inlay
12	explanation
13	central control console
15	control box
20	drugs

tab. 1 Position identification numbers of fault message in the MID

6.3 Printing speed indication and auction monitoring

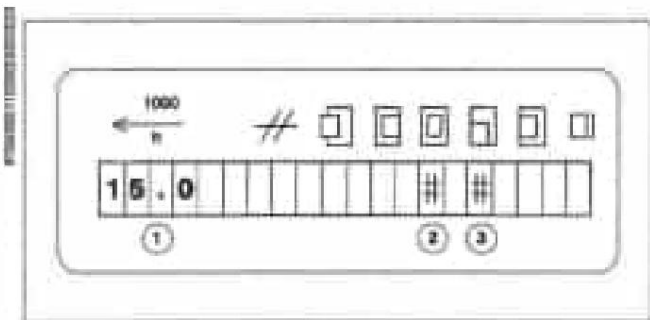

afb. 21

- When the **machine** is at pressure, note of the current printing speed (Fig. 21/©) (display value x 1000; here 15000 pressure/hour).
- When an **error in the auction transport or the auction supply** is determined, indication from # under the relevant symbol (here: slanted sheet, Fig. 21/©, and sheet running error afb. 21/©).

Depending on the type of error, an **acoustic warning signal** or the inlay may also be heard is turned off or the machine is stopped.

Controlling the machine

5.4 Aanwijzing schuin vel

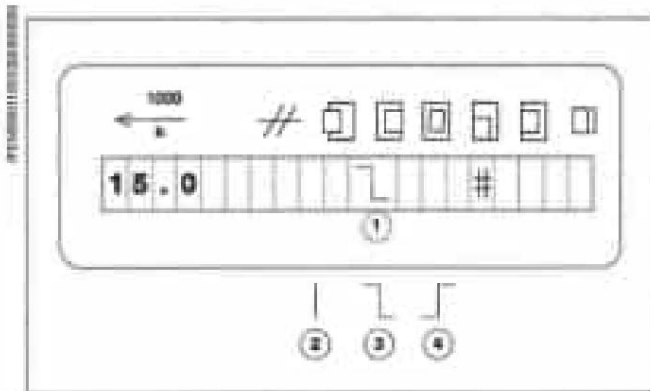

afb. 22 Aanwijzing schuin vel

• During paper flow or production

The **sheet insertion control** uses sensors to detect the inclination of the sheet at the front. The tilt is shown as a line symbol in the MID (fig. 22/0); here: slanted sheet, too large settlement at AZ.

Messages: good sheet (Fig. 22/@), slanted sheet, too large unwind AZ (Fig. 22/3), slanted sheet, too large unwind BZ (Fig. 22/4)

The message does not affect the control of the machine. Check the auction run if there is a recognizable trend. If necessary, correct the suction head manually.

6.5 Indication: SETTING LIMIT REACHED

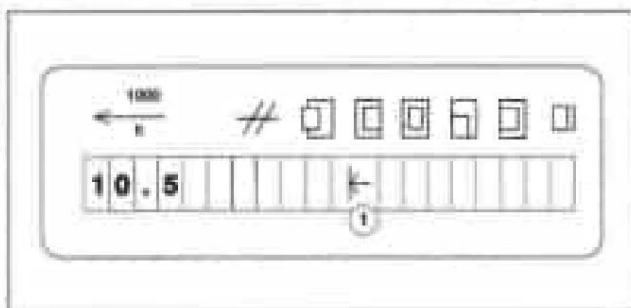

afb. 23 STELGRENS BEREIKT

• If the **sheet arrival arrangement** exceeds the **limit of reaches the control range.**

The indication SETTING LIMITS REACHED (fig. 23/Q) is only visible if no adjustments are made in the MID, error messages, malfunctions or other information are provided.

This instruction does not affect the control of the machine.

• If this message appears, check the paper flow and the settings of the feed rollers and the insert.

6.6 Aanwijzing oplageteller

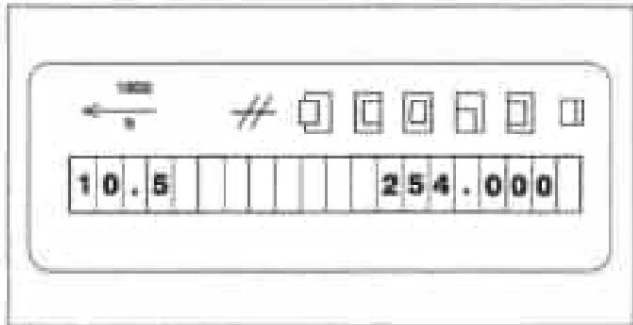

afb. 24 Oplageteller

- If no error message is given by the sheet monitoring
- and the speed of the suction belts or the rotational speed of the baking roller is not changed
- and no fault indication is given.

The **insert MID** indicates the number of sheets still to be printed on (here 254000), the **explanation MID indicates** the number of sheets already printed.

Counting direction; input MID counting down, explanation MID counting down.

O Set counter: see chapter C Presetting
gen.

0 Start or interrupt counter: CONTACT button

Operate COUNTER ON/OFF on the inlay control console.

The resulting misprints are not included in the MID indicated but in the display of the central control console.



afb. 25 Oplage bereikt

When the circulation limit is reached, the insert MID shows a sum symbol and the number of sheets in the machine (fig. 25) (here S = 10 printing sheets).

The blowing and suction air is also supplied to the insert turned off, the remaining sheets remain in the machine are printed and transported to the explanation.

Controlling the machine

6.7 Indication of the sheet monitoring

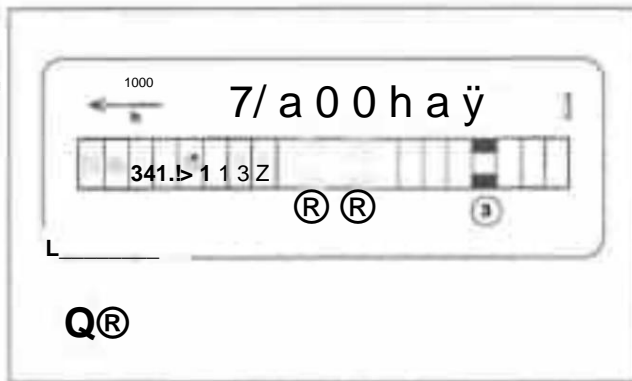
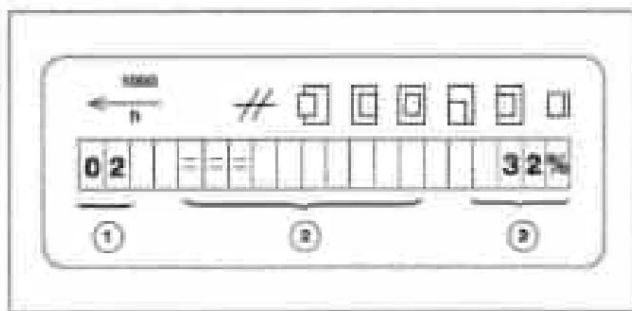

Fig. 26 Auction monitoring

- When the PROTECT key has been operated (LED brandt)
- ⊙ Early and surplus sheet check
- ⊙ Sheet insert control
- ⊙ Side construction control
- ⊙ Security AZ (black box above), security BZ (black box below)
- When the machine is stationary: adjust and regulate of the surveillance facilities.

At a higher printing speed than 3500 sheets/hour, stripes appear in the display; a check is not more possible.

6.8 Aanwijzing van het bakroltoerental



afb. 27 Bakroltoerental

- When operating the keys
 - + moisture DW 1 to 8,
 - moisture DW 1 to 8
- ⊙ Position identification number of the selected unit
 - (02 = printing 2)
- ⊙ Current speed as graphical representation (= 10% each time)
- ⊙ Current speed as percentage indication: 32%
- Change the baking roller speed by the appropriate setting button.

The percentage display changes by 2% each time the key is pressed, the graphic display changes in steps of 10% each time. The display will switch back to the current machine data after approx. 5 s.

6.9 Indication of the speed of the suction belts

When pressing the SUCTION BELTS FAST or keys SUCTION BELTS SLOWLY

appears in the explanation display, for example:

„12=== 32%”.

The percentage display changes by 2% each time the key is pressed, the graphic display changes in steps of 10% each time. The display will switch back to the current machine data after approx. 5 s.

6.10 Aanwijzing service-code

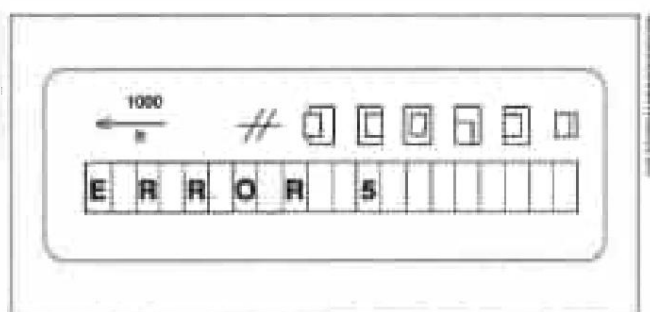

afb. 28 Service-code

• If a functional fault is detected during the self-test,

an error message appears, e.g. "ERROR 5".

○ Notify Heidelberg service.

The service code is an indication for the service technician as to the cause of the malfunction.

Controlling the machine

7 CPTronic control console

7.1 Machine met CPC

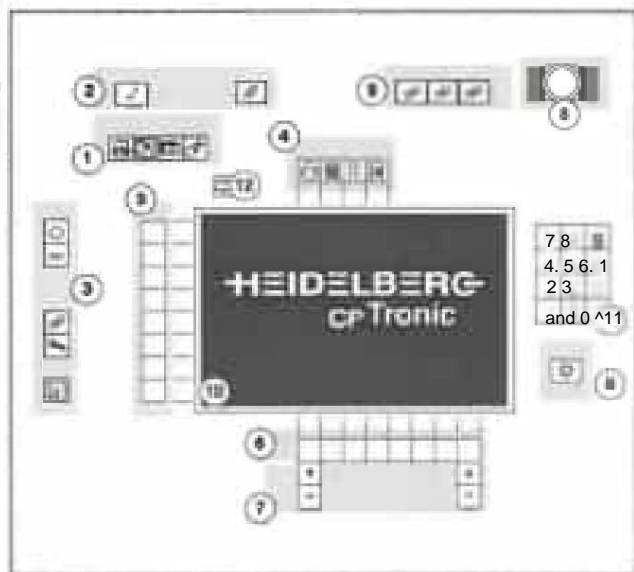

afb. 29

- ⊙ Command keys: preset, command change, scale press, to wash.
- ⊙ Command control keys input, clear
- ⊙ Display buttons: preselection, current value, faults, service, fine display
- ④ Selection buttons UNIT: entire machine, explanation, printing, inlay
- ⊙ Selection buttons GROUP/PRINTED MATTER
- ⊙ Function keys
- ⊙ Adjustment buttons (+/- buttons)
- ⊙ Machine keys EMERGENCY STOP and STOP
- ⊙ Fault detectors
- ⊙ Centrale display
- ⊙ Numeric keypad
- ⊙ BROWSE key for more printed matter/physical groups (only for machines with turning device or more than 8 colours)

7.2 Machines without CPC

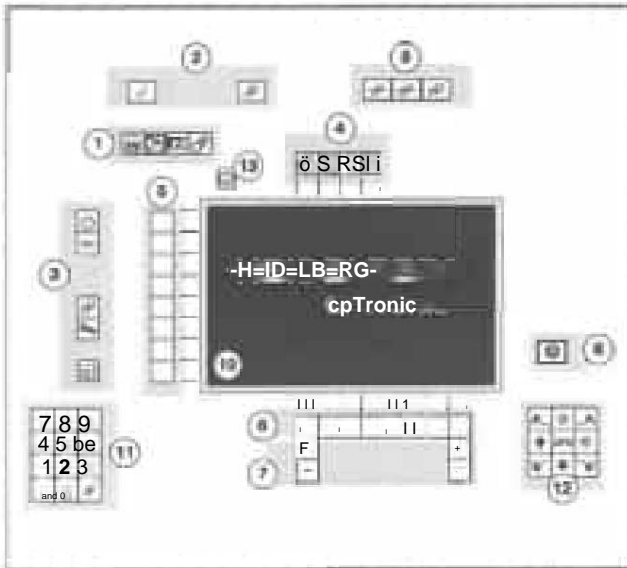

afb. 30

- | 0 Command keys: preset, command clear
- | sel, scale printing, washing,
- ⓪ Command control keys: input, clear
- i @ Display buttons: preselection, current value, faults, service, fine display
- ⓪ Selection buttons UNIT: entire machine, explanation, printing, insert
- ⓪ Selection keys GROUP/PRINTED MATTER
- ⓪ Function keys
- 0 Adjustment buttons (+/- buttons)
- ⓪ Machinetoets STOP
- ⓪ Fault detectors
- ⓪ Centrale display
- 0 Numeric keypad
- ⓪ Register and bucket roll functions (only for machines without CPC control)
- ⓪ BROWSE key more printed/physical groups (only for machines with turning device or more than 8 colors)

7.3 Function of the keys

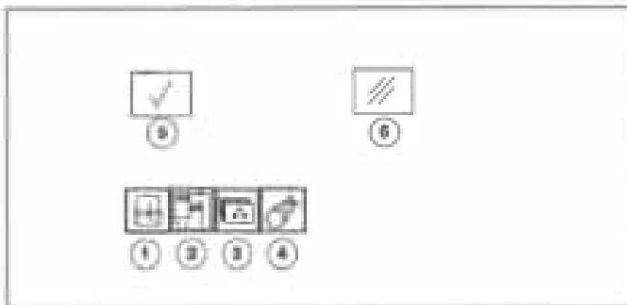

afb. 31

- | **Commandtoetsen** (afb. 31/0 t/m ⓪)
- | The yellow command keys activate program controlled instructions from the central control are initiated or initiated.
- ⓪ Preset
- ⓪ Assignment change
- ⓪ Scale Prints
- ⓪ Wash

Command control keys (fig. 31/⓪ and ⓪)

- ⓪ INPUT (green) starts execution.
- ⓪ CLEAR (red) interrupts the execution or initialization of the command.

Controlling the machine

-H=ID=LB=RG-

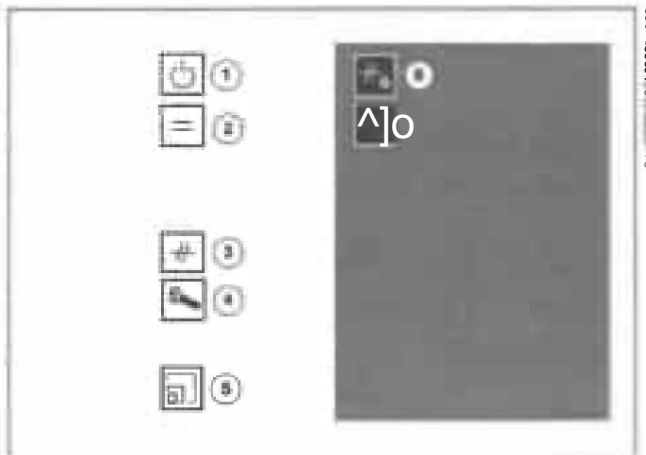

afb. 32

Indication keys

© PRE-SELECTION NOTE

All functions related to printing are preset selected and shown in the central display. During paper flow and at the start of printing, the pre-selected functions will be in the correct order activated. After a machine stop, Restart of printing takes over the adjusted functions of the preset.

@ INDICATION CURRENT VALUE

The components or functions of the machine are then switched on or off directly has changed. The function control via the display of the current value works directly on the machine.

© TROUBLESHOOTING NOTICE

Fast localization of faults in the control panel display with the UNIT keys. A flashing field below the UNIT selection buttons indicates in which part of the machine a fault has occurred. The fault detectors (red - blue - yellow)

indicate the type of fault. The operator can use the selection keys GROUP to choose between the directions:

Machine fault (Fig. 32/©) (machine not ready for operation) Production fault (Fig. 32/©) (warning) With the selection keys GROUP for example, individual print works are selected to locate the fault.

© SERVICE INSTRUCTIONS

The service manual provides instructions for: the cause of a machine defect. These instructions are a valuable aid the service technician; This allows him to prepare specifically for the repair work required each time.

© FINE VIEW

Details see Fig. 34.

Controlling the machine

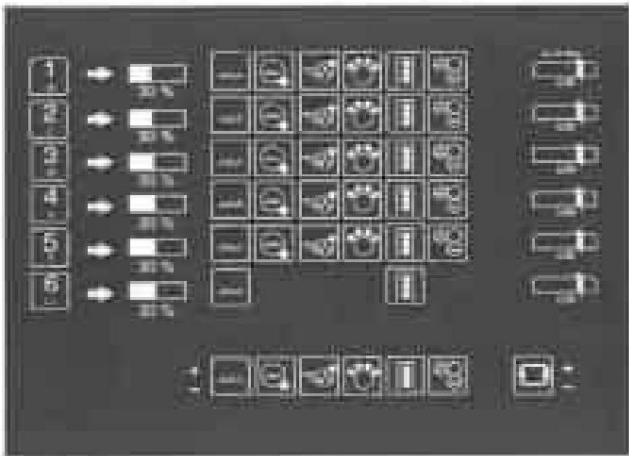

afb. 33

Fine display not selected: display of the symbols as a block (Fig. 33).

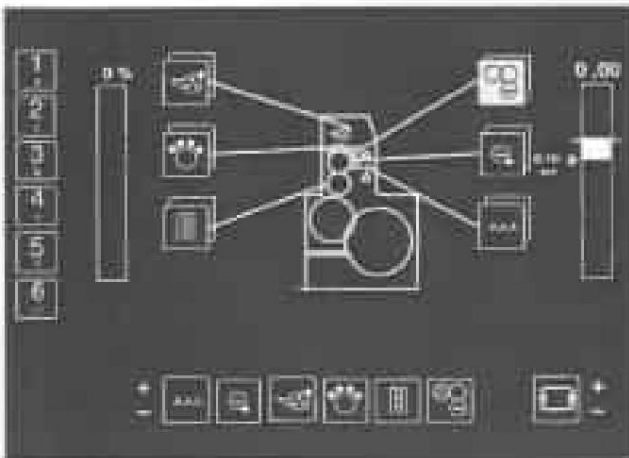

afb. 34

Fine display selected: display of a diagram that makes it easier to assign the symbols (Fig. 33). When the PRE-SELECT prompt mode is selected, blank rectangles appear to indicate that the settings are being stored in memory.



afb. 35

Unit selection keys

This key group allows you to preselect a machine unit to check or change its status. By choosing a specific unit the previous choice is undone.

© ENTIRE MACHINE

© EXPLANATION

@ PRINTING ©

INLEG

Controlling the machine

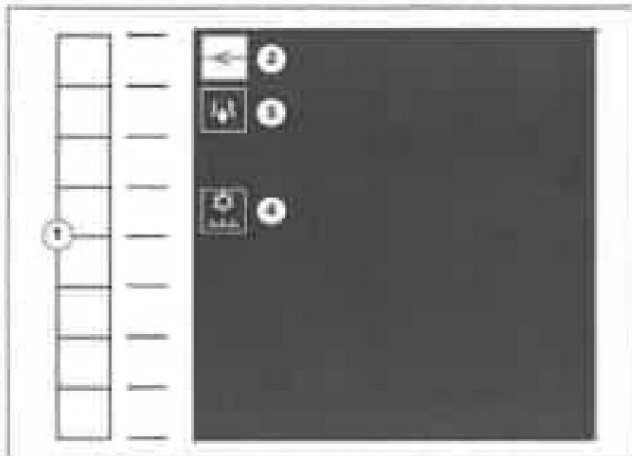

afb. 36

Selection buttons GROUP/PRINTED MATTER

The groups are shown in the display by means of symbols or the printed matter indicated by the numbers 1 to 8; This is activated with the adjacent group/print keys (Fig. 36/©).

- Unit key ENTIRE MACHINE

You can use the GROUP selection buttons (fig. 36/©). the following aggregates or functions are selected

paper flow (fig. 36/©)

vacuum units (fig. 36/@)

cooling (fig. 36/®)

- unit key PRINTED MATTER

A printed matter is selected using the GROUP selection keys.

Assigning the printed matter to the keys are done via the display.



afb. 37

If no GROUP selection key is pressed,

all printed matter selected, including those that are not displayed. This is done using the illuminated arrows (fig. 37/©) next to the printed matter numbers was



afb. 38

Selecting individual printed matter: A selection key Press GROUP. The key, the number of it printed matter (fig. 38/©) and the arrow next to it light up.

To deactivate printed matter: press another selection button GROUP.

Select all printed matter again: unity key Press PRINT.

- Unit key ENTRY

The GROUP keys can be used to select the following functions:

© Papierloop

@ Velinloop

@ Format adjustment

® Stack (chosen here)

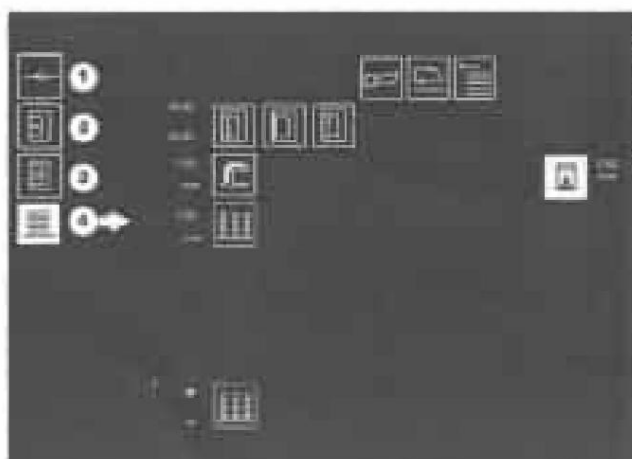

afb. 39

